



Water Pumping

Polyethylene or polyester pumping stations for:

Single family home



Small collective



Collective



Techneau

A competence centre at your service

Demonstration of our involvement in sailing sports: The Class 40 Techneau sailing boat has participated in the famous transatlantic solo race "Route du Rhum 2010".

Located in Normandy, on an industrial site of 8 hectares, Techneau has developed internally all skills for design, development, manufacture and commercialization of its products.

In 1991 the Techneau adventure began focusing on the creation and development of innovative products designed for the water pre-treatment and the water pumping.

In 1998, Techneau created the Plasteau company in order to jointly develop the production of rotomoulded single-piece polyethylene hollow tanks.

Specialized in the production of single-piece hollow bodies of large volume dedicated to the management and reclamation of rain water for the industry sector and local communities, Plasteau is equipped with 5 machines **able to produce spheres till 15000 L.**

Recognised industrial expertise

The industrial boiler manufacturer, Chaudreau, was created in 2001. This allowed Techneau to industrialize its production tool, while keeping flexibility on customization. Chaudreau is continuing its development to become within 12 years a major and well-known actor in the production of:

- moulds for plastic and polyester industries,
- hydraulic equipment (penstocks and flow controllers),
- units for water pre-treatment and treatment,
- floor equipment (manhole covers, stainless steel siphons and gutters)

The production site represents 4130 m² and total surface of offices + annexes is 310 m². The production unit is composed of:

- 1 plasma cutting bench of 2 x 4 m,
- 3 folding presses, 2 shearing machines, 2 rolling machines,
- 1 automated production line,
- 1 painting tunnel,
- 1 second painting area of 80 m²



Research & Development department Inventing tomorrow's products...

Our Research and Development department is composed of 15 technicians and engineers in charge of **studying your needs and anticipating tomorrow's products.**

The Quality unit tests and validates each product before its commercialisation.

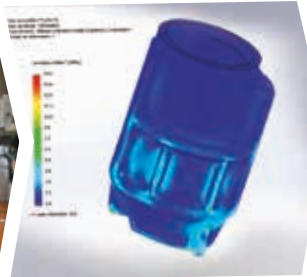

Sales Department
for mainland France

Tel. : **+33 2 33 56 62 08**

Sales Department
for EXPORT

Tel. : **+33 2 33 56 66 43**

A Sales Department as close as possible to meet your expectations

12 area managers together with 9 sedentary technical salesmen are available to study and propose the most relevant technical solutions for your projects and jobsites.

With **more than 25,000 technical offers per year**, Techneau remains close to its initial commitment: guarantee you a precise **customized study within a 24 to 48 hours** deadline.

A large stock at your disposal for an even more efficient responsiveness...

70 references, representing more than 350 units, are always on stock ready to be dispatched on the very same day as your order.

Polyester workshop



Assembly of the STAR1000 pumping stations





Techneau for 27 years,
Design, production, commercialisation:
meet all our competence in a single site
in Normandy



French
 manufacturing for
 all the Europe



*Polyester
 workshop*



Filament winding



*Boiler
 workshop*



*A 4 hectares storage area
 Tests area and logistic solutions*



*Polyethylene
 workshop*



Export department in the office



Export director
Pascal Samson :
 Tel. +33 233 772 117 Mob. +33 684 786 826
 ✉ pascal.samson@techneau.fr



Technical sales-woman
Séverine Prévost-Devillers :
 Tel. +33 233 566 778
 dept. French Polynesia, New Caledonia, Africa,
 Benelux, Spain, Italy, Portugal, Croatia, Czech
 Republic, Slovenia.
 ✉ severine.prevost-devillers@techneau.fr



Technical sales-woman
Stéphanie Kerdual :
 Tel. +33 233 77 58 02
 dept. Greece, Cyprus, Switzerland, Poland, England,
 Ireland, Norway, Germany, Eastern Europe,
 Maghreb.
 ✉ stephanie.kerdual@techneau.fr



Indian Ocean responsible
Henri Glatard :
 Tel. +33 675 229 939
 ✉ henri.glatard@techneau.fr



Technical sales-woman
Corinne Canivet-Lelarge :
 Tel. +33 233 566 624
 ✉ corinne.canivet@techneau.fr



**West Indies / French
 Guiana responsible**
Christophe Maugis :
 Tel. +33 686 289 885
 ✉ christophe.maugis@techneau.fr



Technical sales-man
Kévin Gervaise :
 Tel. +33 233 566 557
 ✉ kevin.gervaise@techneau.fr



*A sales department to provide you
 with information or guide you in
 choosing your product*



Export department on the field

- 1** **Pascal SAMSON**
FR / EN / ESP
Tel. +33 (0)6 84 78 68 26 [✉ pascal.samson@techneau.fr](mailto:pascal.samson@techneau.fr)
- 3** **Julio PAYO**
ESP
Tel. +34 672 18 18 77 [✉ julio.payo@techneau.com](mailto:julio.payo@techneau.com)
- 4** **Pawel DABROWSKI**
PL / EN
Tel. +48 502 266107 [✉ pawel@techneau.com.pl](mailto:pawel@techneau.com.pl)
- 5** **Lukas ROCEK**
CZ / SK / FR / EN
Tel. +420 602 16 71 72 [✉ rocek@techneau.cz](mailto:rocek@techneau.cz)
- 6** **Bernard ISERENTANT**
BE / NL / EN / D
Tel. +32 475 24 24 77 [✉ b.iserentant@skynet.be](mailto:b.iserentant@skynet.be)
- 7** **Bernard ISERENTANT**
FR / DE / EN
Tel. + 32 475 24 24 77 [✉ b.iserentant@skynet.be](mailto:b.iserentant@skynet.be)
- 8** **Davor JURISIC**
HR / EN / D
Tel. +385 99 475 3110 [✉ d.jurisc@jureko.hr](mailto:d.jurisc@jureko.hr)
- 9** **Gabor FAJCSAK**
HG / EN / D
Tel. +36 704 25 9972 [✉ fajcsak.gabor@gmail.com](mailto:fajcsak.gabor@gmail.com)

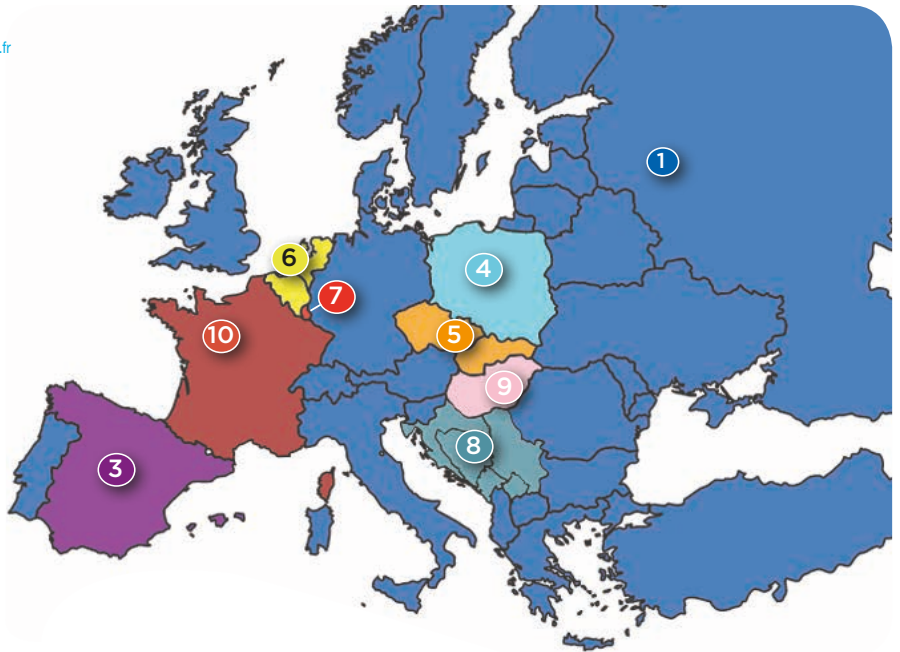

France

- 10** **David LESECOQ**
Sales director
Tel. +33 233 56 66 43
[✉ david.lesecq@techneau.fr](mailto:david.lesecq@techneau.fr)

Export sales administrator / Logistics

Anne SIMON
Tel. +33 233 56 66 43
[✉ anne.simon@techneau.fr](mailto:anne.simon@techneau.fr) or
export@techneau.com

Maintenance department



Commissioning Department Manager

Emmanuel Aumont:
Tel. +33 2 33 77 21 19
[✉ emmanuel.aumont@techneau.fr](mailto:emmanuel.aumont@techneau.fr)

Assistant:
Nadine Mesnil:
Tel. +33 2 33 77 21 11
[✉ nadine.mesnil@techneau.fr](mailto:nadine.mesnil@techneau.fr)

Floor equipments Department





Operating principles of the pumping stations

The start and stop of the pump of a pumping station are triggered by the water level in the tank.

Operating principle with 1 pump

Normal operating cycle: the water rises into the tank and reaches **level 2**: the level float triggers the start of the pump. The level decreases down to **level 1**: the level float stops the pump. If **level 3** is reached, the alarm float (optional) triggers a sound and visual signal warning about the overflowing risk.

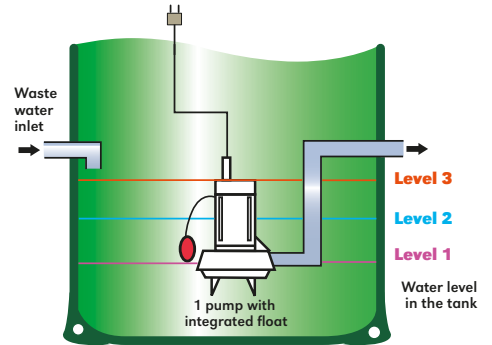

Operating principle with 2 pumps



The Piezo probe system operates with pressure measurement. It is reliable and accurate. The front interface provides the station's operating status.

Normal operating cycle: the water rises in the tank and reaches **level 2**: the pressure sensor triggers the start of one of the 2 pumps. The level decreases down to **level 1**: the box stops the pump. At the next cycle, the other pump will be started: it is called operating alternation.

Operating cycle in case of pump failure or overloading: **in case of a pump failure, the functioning pump is always triggered a level 2.**

In the situation of an overloading, the effluent rises into the tank and reaches level 2: the pressure sensor starts one of the 2 pumps. The level continues to rise and reaches **level 3**: the second pump is then triggered; in that case there is a simultaneous operation of the 2 pumps.

Damaged operating mode: if **level 4** is reached, the alarm float triggers the 2 pumps as well as sound and visual signal warning about an overflowing risk. The stop of the 2 pumps will be performed by the alarm float.

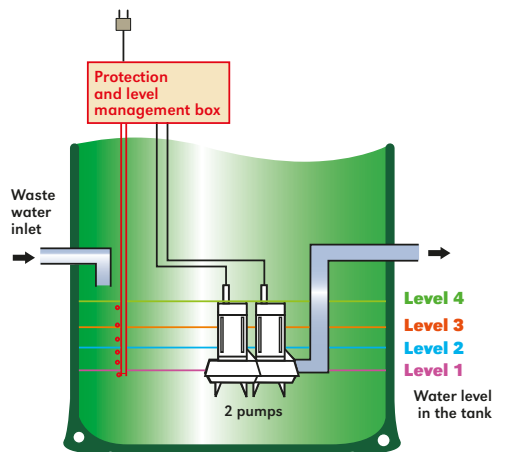

2 possible installation types

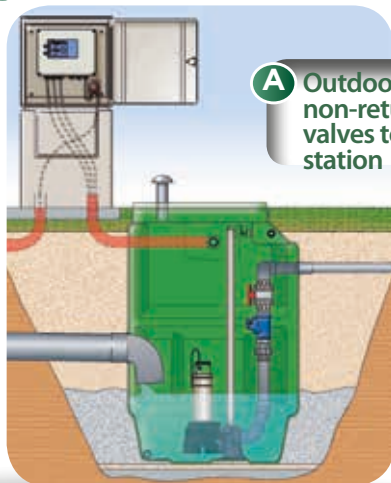

A Outdoors with integrated non-return valves and valves to the pumping station

STAR900 schematic diagram with ventilation and external electrical box

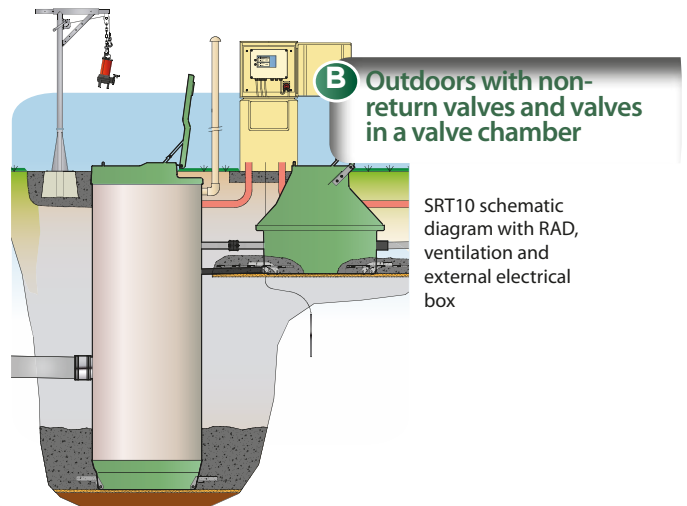

B Outdoors with non-return valves and valves in a valve chamber

SRT10 schematic diagram with RAD, ventilation and external electrical box

Selecting his pumping station for

single family home

Table of contents

from 01 to 10 users



STAR 150 1 tripod pump	12
STAR 700 & 710 1 tripod pump	14
STAR 700 & 710 1 pump on foot bracket	16

Single family home

small collective

from 11 to 49 users



STAR 900 1 pump on Dn 65 foot bracket	20
2 pumps on Dn 50 foot bracket	22

small collective

collective

from 50 to 200 users



STAR 1000 2 pumps on foot bracket Dn 50	26
Dn 65	28
STAR 1200R Integrated valve chamber 2 pumps on foot bracket Dn 50	30
Dn 65	32
SRT 10 2 pumps on foot bracket Dn 50	34
Dn 65	36
Dn 50 with valve chamber	38
Dn 65 with valve chamber	40

Collective

Technical guide



new



Pumping station study: the form	44
The total head (TDH): make your own calculation	45

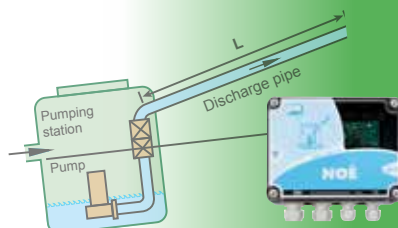

The electrical control boxes operation and protection	46
Installation principles STAR and SRT ranges	48
The commissioning	54
The maintenance operations	55
The norms and CE marking	56
The device taking back form	57

Technical guide



Selecting the buried pumping station:



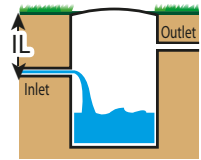



An Inlet Level (IL) for each device

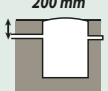

The rating of the **Inlet Level (IL)** is crucial in selecting your pumping station for a buried installation outside a building.

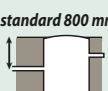

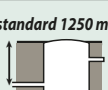
Single family home: 1 to 10 users

Inlet Level depth (IL)	Number of users	Effluent type	Recommended pumping station		Our advice
			Model	Page	
 200 mm	-	Laundry or waste water	STAR 150 	12	Water pumping at garage outlet
 standard 800 mm	1 to 10	Treated or raw waste water	STAR 700 	14	Upstream or downstream installation from an autonomous sanitation chain, 2 ILs available
 standard 1250 mm	1 to 10	Treated or raw waste water	STAR 710 	16	



Selection for a single family home, depending on the geometrical height and discharge length

A With Dn 32 (1" 1/4) or Dn 40 (1" 1/2) PVC discharge pipe:

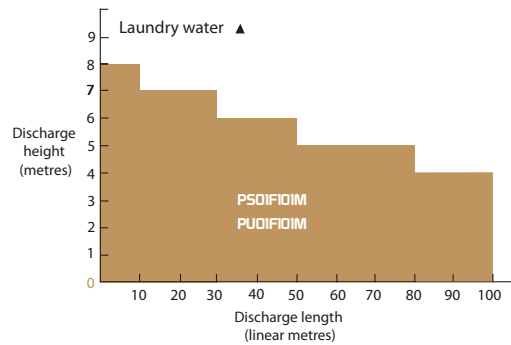
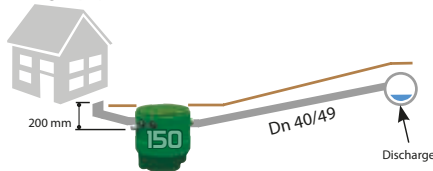

B With Dn 50 (2") PVC discharge pipe:

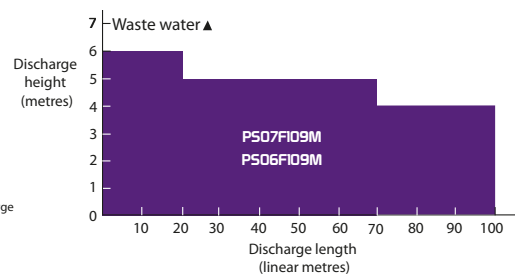
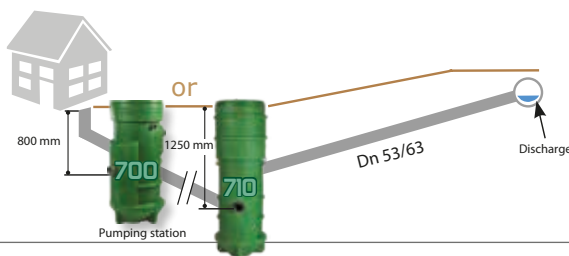

C With Dn 65 (2" 1/2) PVC discharge pipe:

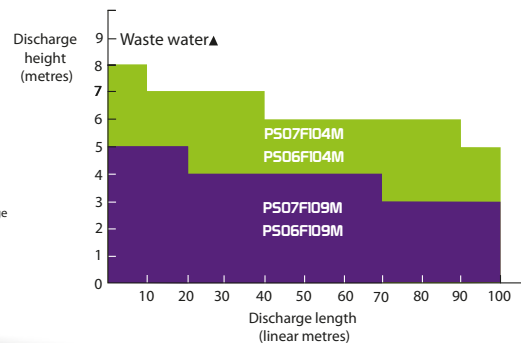
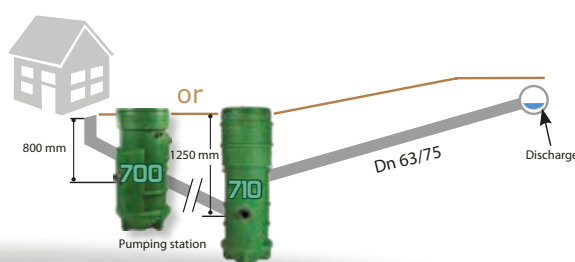



Selecting the buried pumping station:

An Inlet Level (IL) for each device

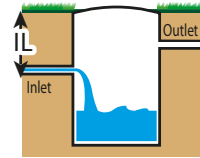

The rating of the **Inlet Level (IL)** is crucial in selecting your pumping station for a buried installation outside a building.

Small collective - 11 to 49 users Dimensions in mm

Inlet Level depth (IL)	Number of users	Effluent type	Recommended pumping station		Our advice
			Model	Page	
 standard 900 mm	11 to 49	Raw waste water and black water	 STAR 900	20	Pumping station fully adapted to public places
 400 or 900 mm	11 to 49	Raw waste water	 STAR 900	22	Great choice of pumps for 2 possible IL

Collective - 50 users and more Dimensions in mm

Inlet Level depth (IL)	Number of users	Effluent type	Recommended pumping station		Our advice	
			Model	Page		
 1200 or 1700 mm	50 to 100	Raw waste water	 STAR 1000	26	Particularly adapted for subdivisions. 2 ILs available, PUE model	
	101 to 200			28		
 > 1730 mm up to 3820 mm	50 to 100	Raw waste water	 STAR 1200 R	30		With integrated valve chamber, PURE model
	101 to 200			32		
 > 1700 mm up to 5200 mm	50 to 100	Raw waste water	 SRT 10	34	Ideal for deep ILs, PUP model	
	101 to 200			36		
 > 1700 mm up to 5200 mm	50 to 100	Raw waste water	 SRT 10	38		With external valve chamber, PURP model
	101 to 200			40		



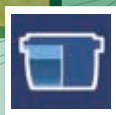

Pumping stations
for **single
family home**

Star150 1 tripod pump _____ p.12-13

Star700 & 710 1 tripod pump _____ p.14-15

Star700 & 710 1 pump on foot bracket _____ p.16-17





STAR150 1 tripod pump



Model shown
PS07F101M

The+product

Station designed for
a shallow installation

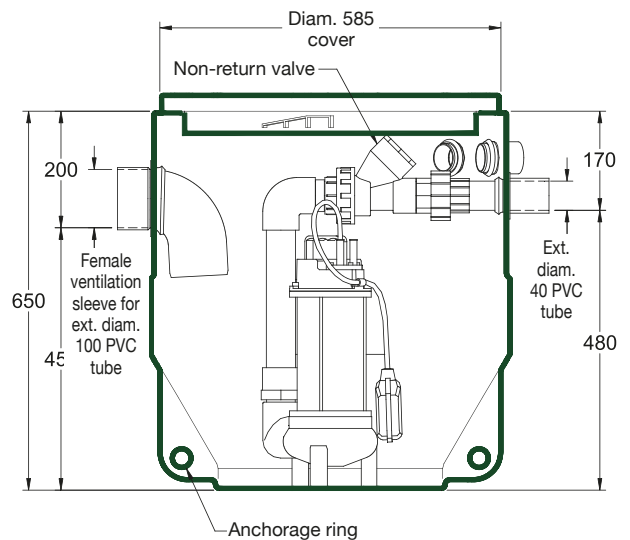
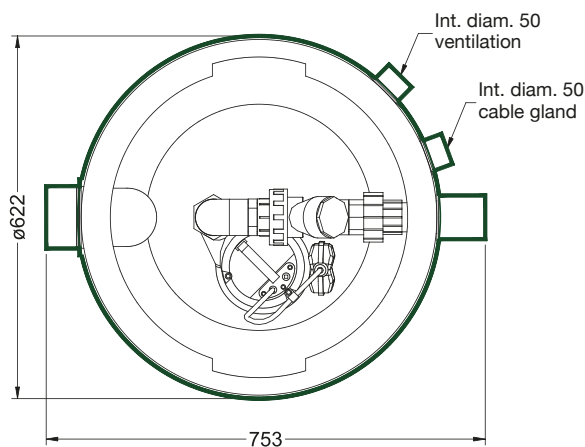

Usage

- Adapted for waste or low-waste (after treatment) water of a single family home.
- Designed for a buried installation outside a building.

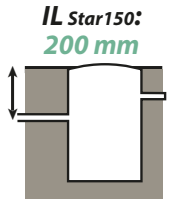

Design

- Polyethylene and corrosion-proof tank.
- Sloping bottom to help with the discharge of muds and to avoid H₂S gas forming.
- 2 anchorage rings.
- Useful volume under inlet level: 125 L.
- Cover closure 1/4 turn locked with 1 nut for additional safety.
- Female PVC entry sleeve to stick for external diam. 100 PVC tube.
- External diam. 40 PVC pressure outlet tube.
- Female PVC ventilation sleeve for external diam. 50 PVC tube.
- Cable gland sleeve, female PVC with stopper for external diam. 50 PVC tube.

Internal equipment

- 1 submerged 230 V single-phase pump: Feka 600 model (see opposite data),
- PN16 PVC pressure discharge pipe,
- PVC Dn 32 ball check (non-return) valve.

STAR₁₅₀



The pump



**LAUNDRY
OR
WASTE WATER**

- 230 V single-phase.**
- Construction:** pump housing, Vortex wheel and polymer engine cover.
- Integrated float.**
- Protection:** Insulation class F IP68.
- Usage:** low waste water
- Cross section:** 25 mm.
- Discharge:** 1"1/4.
- Connection only with 230 V plug + earth.**
- Equipped with a 5 m cable.
- Weight:** 7.2 kg.

01 FEKA 600 M Auto

Model selection

depending on the rate and on the Total Head (TDH)
If you don't know them, please refer to page 9 to select it or to page 45 to calculate them.

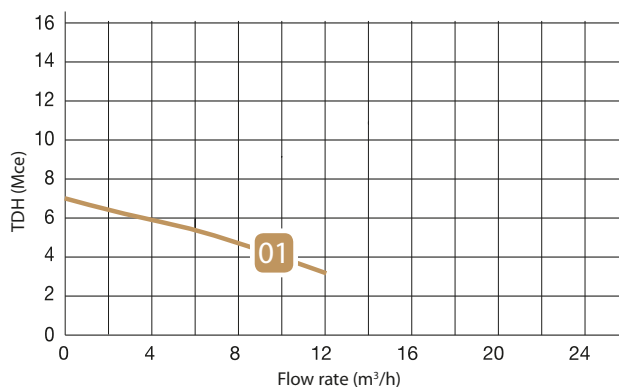

Options



Polyethylene extensions

Fixed height 200 mm.
Fixed height 400 mm.

PLA13555
PLA13556



Never pile 2 extensions up. It is recommended that the installation is as less deep as possible to help with maintenance and to avoid ground overloads over the tank.



Level float

with a 10 m cable.

RB10

Waterproof connection kit

IP68 for 24h under 2 m of water. Allows to extract the pump or the level regulators from the pumping station without removing the sheaths' cables.

- Single-phase or three-phase pumps of this catalogue **14871**
- Level regulators **14532**



Warning: connection kit required per cable.

new



CP03

Management and control box

RB10 level float required. For max 5A pump.



See detailed description on page 47

Features and technical data

Reference	Curve No./pump	Pump type	Cross section (mm)	Diam. inlet (mm)	Diam. outlet (mm)	Amperage (amperes)	Voltage (volts)	Power (kW)	Station weight (kg)
PS01F101M	01	FEKA 600 M Auto	25	for ext. diam. 100 PVC tube	Ext. diam. 40 PVC tube	4,3	230 V Mono	0,55	18

Texts, dimensions, pictures and diagrams are not contractual.





STAR700 & 710 1 tripod pump



STAR 700 Model
PS07F101M

STAR 710 Model
PS06F101M

Usage

- Adapted for waste or low-waste (after treatment) water of a single family home.
- Designed for a buried installation outside a building.

Design

- Polyethylene and corrosion-proof tank.
- Sloping bottom to help with the discharge of muds and to avoid H₂S gas forming.
- 3 anchorage rings.
- Useful volume under inlet level: 200 L.
- Cover closure 1/4 turn locked with 1 nut for additional safety.
- Female PVC entry sleeve to stick for external diam. 100 tube.
- External diam. 40 or external diam. 63 PVC pressure outlet tube.
- Female PVC ventilation sleeve for external diam. 50 PVC tube.
- Cable gland sleeve, female PVC with stopper for external diam. 50 PVC tube.

IL Star 700 :
Standard 800 mm

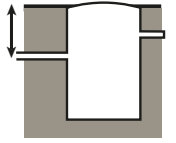

On request from
600 to 900 mm

Standard 1250 mm

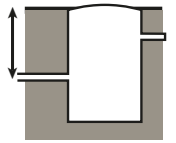

On request from
1050 to 1350 mm

Internal equipment

- 1 submerged pump,
- PN16 PVC pressure discharge pipe,
- PVC Dn 32 ball check (non-return) valve and Dn 32 PVC ball valve mounted on union for No. 1 pump,
- PVC non-return valve with Dn 40 PVC ball check and Dn 40 PVC ball valve mounted on union for No. 9 pump.



Model shown STAR 710
with details of the ball valve

The+product

Station designed
for a deep installation

Texts, dimensions, pictures and diagrams are not contractual.

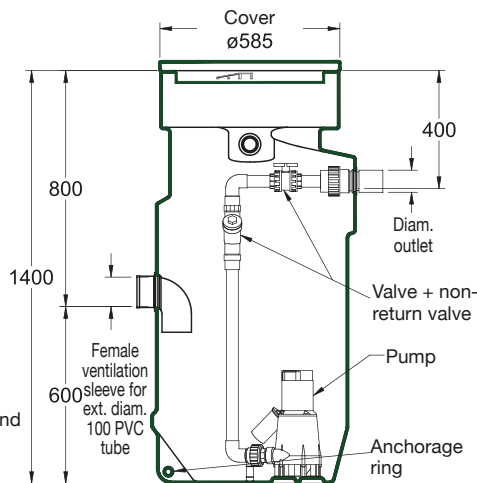
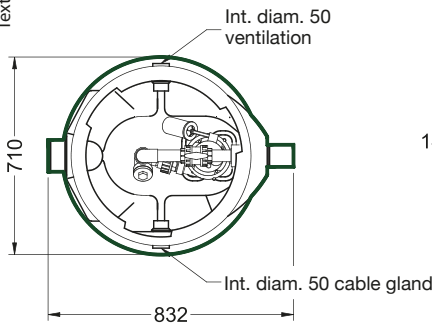

STAR 700 Model

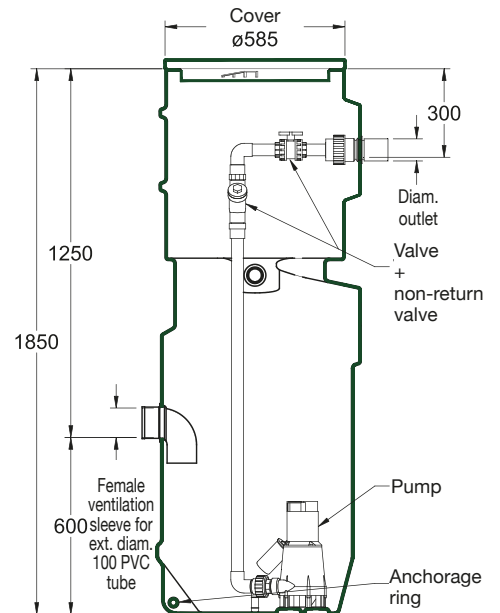

STAR 710 Model

STAR700 & 710



Model selection depending on the rate and on the Total Head (TDH)

If you don't know them, please refer to page 9 to select it or to page 45 to calculate them.

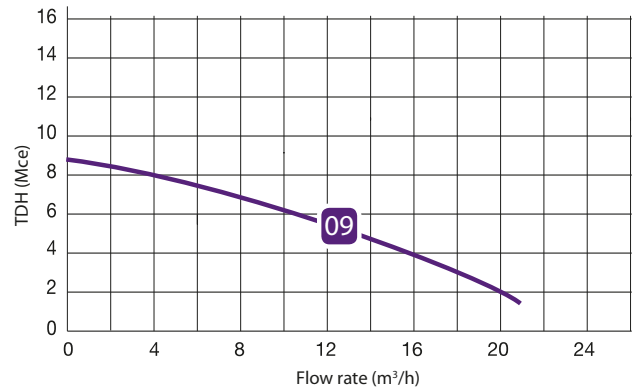
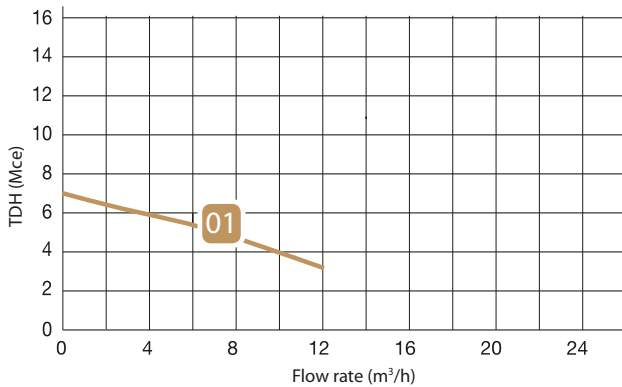

The pump

230 V single-phase.

Integrated float.

Construction:

- FEKA 600M Auto: pump housing, Vortex wheel and polymer engine cover.
- SEMISOM 290M Auto: pump housing and cast-iron Vortex wheel, stainless steel engine cover.

Protection: Insulation class F IP68.

Liquids temperature:

Feka 600: max + 35°C

Semisom 290M: max + 50°C



01 FEKA 600M Auto

**LOW WASTE WATER
AFTER SEPTIC TANKS**

Cross section: 25 mm.
Discharge: 1"1/4.
Power: 0.55 Kw.
Intensity: 4.3 A.
Connection only with 230 V plug + earth.
Equipped with a 5 m cable.
Weight: 7.2 kg.



09 SEMISOM 290M Auto

WASTE WATER

Usage : waste water.
Cross section: 50 mm.
Discharge: 2".
Power: 0.55 Kw.
Intensity: 4.2 A.
Equipped with a 10 m cable.
Weight: 14.5 kg.

Texts, dimensions, pictures and diagrams are not contractual.

Single family home

Options



Drilling kit

KITP100

Full kit with 1 hole saw, 1 seal and 1 stopper. Dn 100. Allows to stop the standard expected inlet and to drill another dn 100 entry depending on your choice.



Polyethylene extensions

Fixed height 200 mm.
Fixed height 400 mm.

**PLA13555
PLA13556**

Never pile 2 extensions up. It is recommended that the installation is as less deep as possible to help with maintenance and to avoid ground overloads over the tank.

new



Management and control box

CP03

RB10 level float required. For max 5A pump.

➔ See detailed description on page 47



Waterproof connection kit

IP68 for 24h under 2 m of water. Allows to extract the pump or the level regulators from the pumping station without removing the sheaths' cables.

- Single-phase or three-phase pumps of this catalogue
- Level regulators

14871

14532

Warning: connection kit required per cable.

Features and technical data

STAR 700 Ht. 1400 mm	Station weight (kg)	STAR 710 Ht. 1800 mm	Station weight (kg)	Curve No./ pump	Pump type	Cross section (mm)	Diam. inlet (mm)	Diam. outlet (mm)	Amperage (amperes)	Voltage (volts)	Power (kW)
PS07F101M	43	PS06F101M	50	01	FEKA 600 M Auto	25	for ext. diam. 100 PVC tube	Ext. diam. 40 PVC tube	4,3	230 V Mono	0,55
PS07F109M	50	PS06F109M	57	09	SEMISOM 290 M Auto	50		Ext. diam. 63 PVC tube	4,2		



STAR700 & 710 1 pump on foot bracket



STAR 700 Model
PU07F104M

STAR 710 Model
PU06F104M

Usage

- Adapted for waste or low-waste (after treatment) water of a single family home.
- Designed for a buried installation outside a building.

Design

- Polyethylene and corrosion-proof tank.
- Sloping bottom to help with the discharge of muds and to avoid H₂S gas forming.
- 3 anchorage rings.
- Useful volume under inlet level: 200 L.
- Cover closure 1/4 turn locked with 1 nut for additional safety.
- Female PVC entry sleeve to stick for external diam. 100 tube.
- External diam. 40 or external diam. 63 PVC pressure outlet tube.
- Female PVC ventilation sleeve for external diam. 50 PVC tube.
- Cable gland sleeve, female PVC with stopper for external diam. 50 PVC tube.

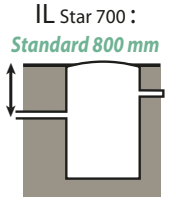

On request from
600 to 900 mm

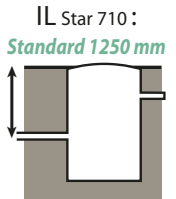

On request from
1050 to 1350 mm

Internal equipment

- 1 submerged pump,
- Foot bracket with composite guiding bars to facilitate the set up of the pump (except for Feka 600M Auto pump: stainless steel guiding bars),
- PN16 PVC pressure discharge pipe,
- PVC Dn 32 ball check (non-return) valve and Dn 32 PVC ball valve mounted on union for No. 1 pump,
- PVC non-return valve with Dn 40 PVC ball check and Dn 40 PVC ball valve mounted on union for No. 9 and 4 pumps.

The +product

The pump on foot bracket allows an easy disassembly without intervention inside the station



Station interior detail
(Semisom 290M Auto on composite foot bracket)

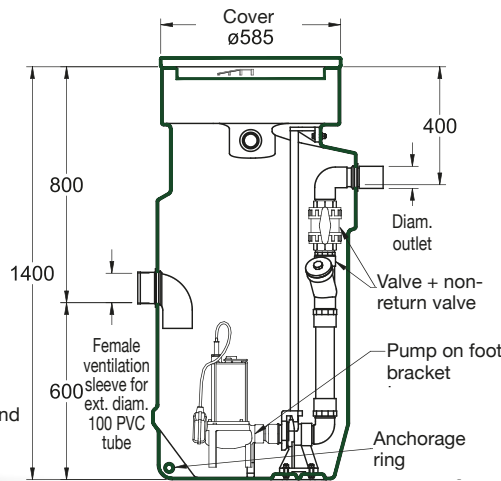
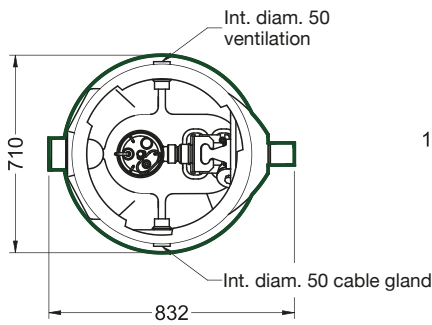

STAR 700 Model

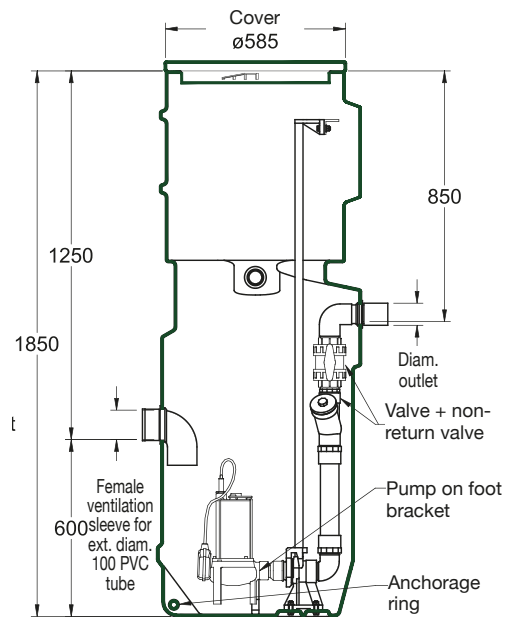

STAR 710 Model

Texts, dimensions, pictures and diagrams are not contractual.

STAR700 & 710



Model selection

depending on the rate and on the Total Head (TDH)
If you don't know them, please refer to page 9 to select it or to page 45 to calculate them.

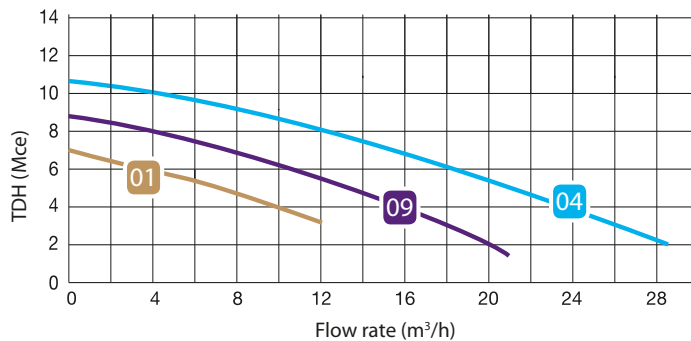

The pump

230 V single-phase.

Integrated float.

Construction: pump housing and cast-iron Vortex wheel, stainless steel engine cover (except for FEKA 600M Auto pump: construction in polymer).

Protection: Insulation class F IP68.

Liquids temperature:
Feka 600: max + 35°C
Semisom 290 and 490M: max + 50°C.



**LOW WASTE WATER
AFTER SEPTIC TANKS**

Cross section: 25 mm.
Discharge: 1"1/4.
Power: 0.55 Kw.
Intensity: 4.3 A.
Connection only with 230 V plug + earth.
Equipped with a 5 m cable.
Weight: 7.2 kg.

01 FEKA 600M Auto



WASTE WATER

Cross section: 50 mm.
Discharge: 2".
Power: 0.55 Kw.
Intensity: 4.2 A.
Equipped with a 10 m cable.
Weight: 14.5 kg.

09 SEMISOM 290M Auto



WASTE WATER

Cross section: 50 mm.
Discharge: 2".
Power: 1.1 Kw.
Intensity: 7.3 A.
Equipped with a 10 m cable.
Weight: 20 kg

04 SEMISOM 490M Auto

Options

new



Management and control box

RB10 level float required. For max 5A pump (non adapted for Semisom 490M Auto pump).

CP03

See detailed description on page 47



Level float with a 10 m cable

RB10



Drilling kit

KITP100

Full kit with 1 hole saw, 1 seal and 1 stopper. Dn 100. Allows to stop the standard expected inlet and to drill another dn 100 entry depending on your choice.



Polyethylene extensions

PLA13555

PLA13556

Fixed height 200 mm.
Fixed height 400 mm.
Never pile 2 extensions up. It is recommended that the installation is as less deep as possible to help with maintenance and to avoid ground overloads over the tank.



Waterproof connection kit

IP68 for 24h under 2 m of water. Allows to extract the pump or the level regulators from the pumping station without removing the sheaths' cables.

• Single-phase or three-phase pumps of this catalogue **14871**

• Level regulators **14532**



Warning: connection kit required per cable.

Features and technical data

STAR 700 Ht. 1400 mm	Station weight (kg)	STAR 710 Ht. 1800 mm	Station weight (kg)	Curve No./ pump	Pump type	Cross section (mm)	Diam. inlet (mm)	Diam. outlet (mm)	Amperage (amperes)	Voltage (volts)	Power (kW)
PU07F101M	40	PU06F101M	47	01	FEKA 600 M Auto	25	for ext. diam. 100 PVC tube	Ext. diam. 40 PVC tube	4,3	230 V Mono	0,55
PU07F109M	46	PU06F109M	53	09	SEMISOM 290 M Auto	50		Ext. diam. 63 PVC tube	4,2		
PU07F104M	67	PU06F104M	74	04	SEMISOM 490 M Auto	50			7,3		

Texts, dimensions, pictures and diagrams are not contractual.

Single family home







Pumping stations for **small collective**

Star900 1 pump on Dn 65 foot bracket — p.20-21

Star900 2 pumps on Dn 50 foot bracket — p.22-23



STAR900 1 pump on Dn 65 foot bracket



The+product
 Model particularly adapted
 for public places.
 Non-clogging pump.



Height 1,50 m
 ref. PU15F103M

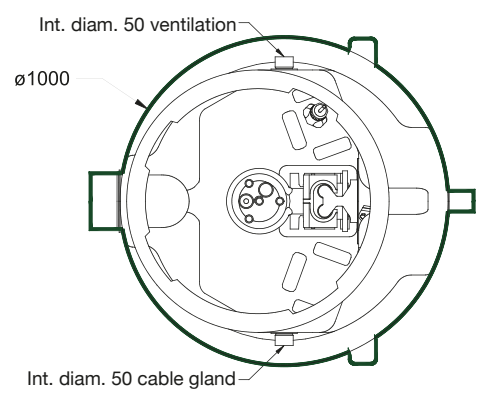

Usage

- Adapted for the pumping of heavy waste water in small collective.
- Designed for a buried installation outside a building.

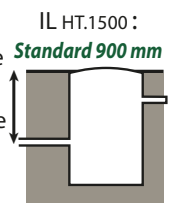

Design

- Polyethylene tank with corrosion-proof anchorage rings.
- Useful volume under inlet level: 400 L.
- Cover closure 1/4 turn locked with 1 nut for additional safety.
- Female PVC entry sleeve to stick for external PVC diam. 160 tube.
- External diam. 75 PVC pressure outlet tube.
- Female PVC ventilation sleeve for external diam. 50 PVC tube.
- Cable gland sleeve, female PVC with stopper for external diam. 50 PVC tube.

On request from
 400 to 900 mm

Equipment

- 1 submerged pump with its starter box,
- Cast-iron foot bracket system and stainless steel guiding bars (help to set up the pump),
- PN16 PVC pressure discharge pipe,
- Cast-iron non-return valve with Dn 65 ball check and Dn 65 PVC ball valve mounted on union,
- 1 alarm float.

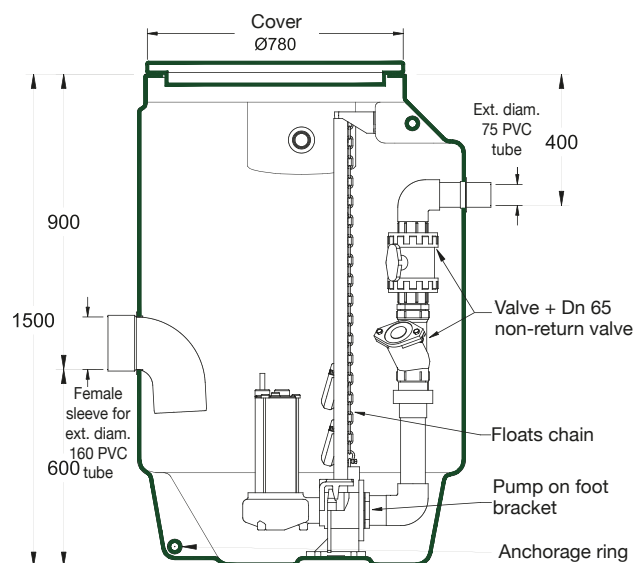

Total weight: 150 kg

> 11 to 49 users

STAR900



The pump

PARTICULARLY ADAPTED
TO PUBLIC PLACES
NON-CLOGGING



Single-phase 230 V or three-phase 400 V.

Model with big cross-section.

Construction:

Pump housing and cast-iron Vortex wheel. Stainless steel engine cover and rods.

Protection: Insulation class F IP68.

Liquids temperature: max + 50°C

Usage: heavy liquid

Cross section: 65 mm

Discharge: 2"1/2

Power 1.5 Kw

Intensity: 12 A (single 230 V) or 4.6 A (three-phase 400 V)

Equipped with a 10 m cable with 2 wires for Ispotherm

Weight 21 kg

03 SEMISOM 650M or T

11 SEMISOM 650H M or T

Model selection

depending on the rate and on the Total Head (TDH). If you don't know them, please refer to page 45 to calculate them.

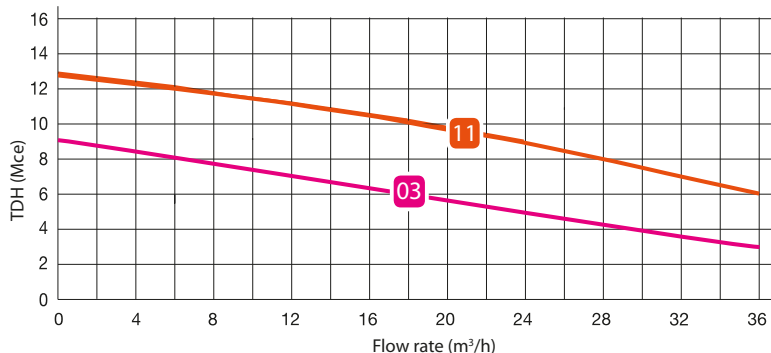

Supplied with:



Three-phase 400 V pump
Starter and protection box with alarm.

CP01RS

Usage

- **Control and protection box:** protects the pump's engine from over-current or blocking.

Technical features

- Three-phase 400 V.
- IP55 waterproofness
- Unpluggable electronic card
- On/off switch, sound alarm, ON indicator, power supply indicator, disjunction indicator.
- Alarm transfer terminal block
- Terminal block to plug in an alarm regulator
- Power supply connection to a bipolar or tripolar protection/disconnection device (EN 60204 standard)
- **Dimensions: L250 x D120 x H180 mm**
- Forced march

Or



Single-phase 230 V pump
Starter and protection box with condensers and alarm

CD650-EVOL

Usage

- **Water-proof control and protection box:** protects the pump's engine from over-current, over-heating or blocking.

Technical features

- Single-phase 230 V
- IP55 waterproofness
- On/off switch, ON indicator, power supply indicator, failure indicator.
- Terminal block to plug in an alarm regulator taking over in case of main float failure
- Power supply connection to a bipolar or tripolar protection device (EN 60204 standard)
- **Dimensions: L230 x D130 x H300 mm**

Single-phase references	No. curve/pump	Pump type
PU15F103M	03	SEMISOM 650 M
PU15F111M	11	SEMISOM 650H M

Three-phase references	No. curve/pump	Pump type
PU15F103T	03	SEMISOM 650 T
PU15F111T	11	SEMISOM 650H T



Warning

Our boxes connect on a power supply equipped with a protection and bipolar or tripolar disconnection device, depending on the cases, complying with EN 60204 standard.

Options

Cover extensions

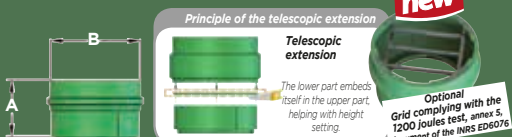

From the second embedded extension, the concrete slab is required. It is recommended that the installation is as less deep as possible to help with maintenance and to avoid ground overloads on the tank.

References	A (mm)	B (mm)	Weight (kg)	Telescopic	Safety grid
ETRA7EF	490	780	10,5 kg	•	GI0670I
ETR65EF	650	780	18 kg	•	

new

Optional Grid complying with the 1200 Joules test, annex 5 document of the INRS E26076

Cabinet with base for outdoors installation

Polyester. L540 x H520 x D240 mm + base height 580 mm. To install a 1 or 2 pump electrical box.

CP510

Anchorage kit

3 steel items. Containing a tank bracket and a welded mesh: the kit helps with tank anchoring in case of ground water.



Weight: 8.5 kg

OSE73050

Texts, dimensions, pictures and diagrams are not contractual.

Small collective



STAR900 2 pumps on Dn 50 foot brackets



Usage

- Adapted for the pumping of water in small collective,
- Designed for a buried installation outside a building

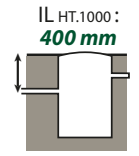

Design

- Polyethylene tank with corrosion-proof anchorage rings.
- Useful volume under inlet level: 400 L.
- Cover closure 1/4 turn locked with 1 nut for additional safety.
- Female PVC entry sleeve to stick for external PVC diam. 160 tube.
- External diam. 63 PVC pressure outlet tube.
- Female PVC ventilation sleeve for external diam. 50 PVC tube.
- TPC diam. 76/90 cable gland sheath.

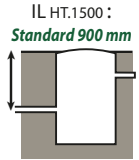

On request from
400 to 900 mm



*Commissioning:
please consult us*

Model shown:
ref. PU15P216M

Internal equipment

- 2 submerged pumps,
- Composite foot brackets and guiding bars to facilitate the set up of the pumps ,
- 2 PN16 PVC pressure discharge pipes,
- 2 PVC ball check (non-return) valves and 2 Dn 50 PVC ball valves mounted on union,
- 1 alarm float (10m cable),
- 1 stainless steel piezo probe installed on a chain with counterweight (10m cable),
- SRI protection control box.



The+product

*Compact pumping station
available with 2 heights,
depending on your jobsite*

Texts, dimensions, pictures and diagrams are not contractual.

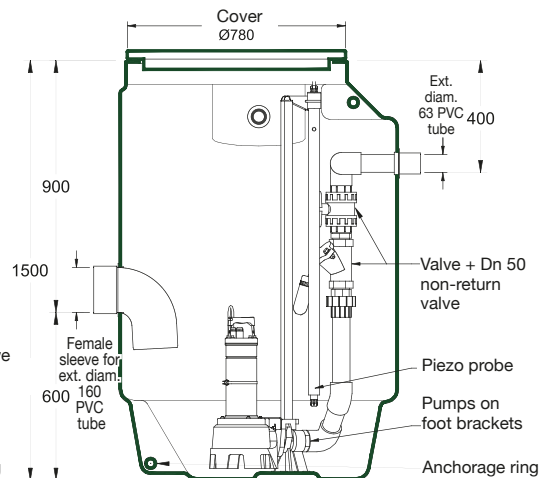
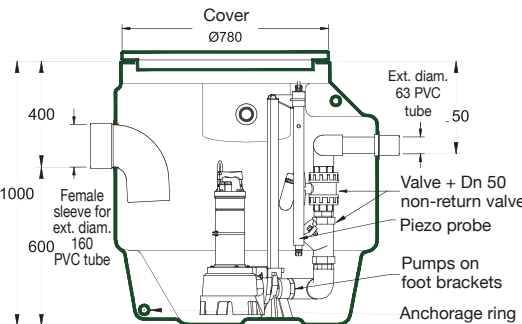
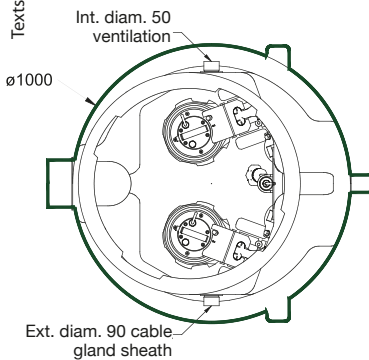

> 11 to 49 users

STAR900



The box and the probe

Technical features

- **Single-phase 230 V or four-phase, 400 V + neutral.**
- Automatic operation of the pumps depending on the tank level.
- Automatic reverse to every start.
- Visual and audible alarm on alarm float.
- Lockable disconnecter.
- Forced March function of the pumps with push-button.
- Pump visualisation March-Disjunction.
- Dry contact for alarm report.
- **Dimensions: L 278 x D 130 x H 378 mm.**

Piezo probe (10 m cable).



For more info, see page 46

Model selection

depending on the rate and on the Total Head (TDH).
If you don't know them, please refer to page 45 to calculate them.

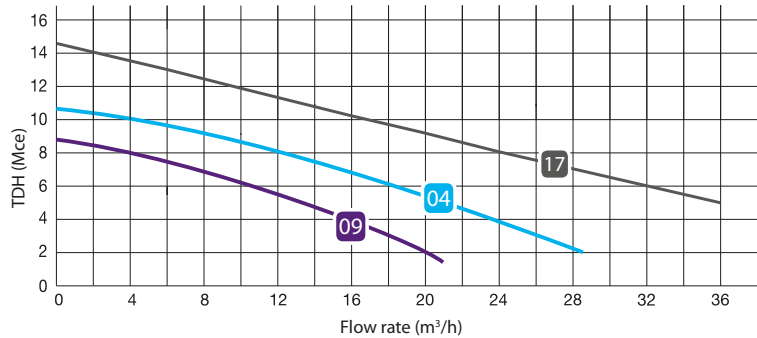

The pumps

Single-phase pumps 230 V with capacitor integrated to the pump for 290M and 490M models.

Capacitors integrated to the box for the 590M model.

Or three-phase pumps 400 V.

Construction:

Pump housing and cast-iron Vortex wheel, steel engine cover,

Protection: insulation class F IP68,

Usage: waste water,

Cross section: 50 mm,

Liquids temperature:

max + 50°C,

Equipped with a 10 m cable.

Discharge: 2",
Weight: 14,5 kg.

09 SEMISOM 290M or T

Discharge: 2",
Weight: 20 kg.

04 SEMISOM 490M or T

Discharge: 2",
Weight: 18,2 kg.
2 wires for Ipsotherm.

17 SEMISOM 590M or T

STAR 900 Ht. 1000 mm	Station weight (kg)	STAR 900 Ht. 1500 mm	Station weight (kg)	No. curve/pump	Pump type	Intensity (amperes)	Voltage (volts)	Power (kW)
PU10P209M	100	PU15P209M	124	09	SEMISOM 290 M	4,2	Single-phase 230 V	0,55
PU10P209T		PU15P209T			SEMISOM 290 T	1,7	Three-phase 400 V	
PU10P204M	105	PU15P204M	129	04	SEMISOM 490 M	7,3	Single-phase 230 V	1,1
PU10P204T		PU15P204T			SEMISOM 490 T	2,7	Three-phase 400 V	
PU10P217M	107	PU15P217M	131	17	SEMISOM 590 M	10,5	Single-phase 230 V	1,5
PU10P217T		PU15P217T			SEMISOM 590 T	4,1	Three-phase 400 V	

Options

Cover extensions

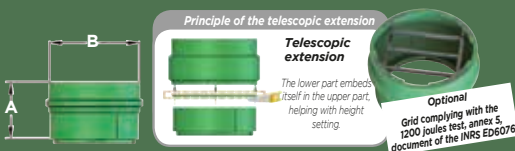

From the second embedded extension, the concrete slab is required. It is recommended that the installation is as less deep as possible to help with maintenance and to avoid ground overloads on the tank.

References	A (mm)	B (mm)	Weight (kg)	Telescopic	Safety grid G10670I
ETR47EF	490	780	10,5 kg	•	•
ETR65EF	650	780	18 kg	•	•



Cabinet with base for outdoors installation

CP510

Polyester.
L540 X H520 X D240 mm + base height 580 mm
To install a 1 or 2 pump electrical box.

Extension cable kit with:

- 1 connection for 2 single or three-phase pumps and 1 alarm float,
- 1 connection for Piezo probe

To install in a chamber or inside the station.

- OS49010** OS49010 for 10 m cable
- OS49020** OS49020 for 20 m cable
- OS49030** OS49030 for 30 m cable



Anchorage kit

OSE73050

3 steel items.

Containing a tank bracket and a welded mesh: the kit helps with the tank anchorage in case of ground water.
Weight: 8.5 kg

Texts, dimensions, pictures and diagrams are not contractual.

Small collective





Pumping stations for **collective** use

Star1000 2 pumps on Dn 50 foot bracket ____ p.26-27

Star1000 2 pumps on Dn 65 foot bracket ____ p.28-29

Star1200R 2 pumps on Dn 50 foot bracket
with integrated valve chamber ____ p.30-31

Star1200R 2 pumps on Dn 65 foot bracket
with integrated valve chamber ____ p.32-33

Srt10 2 pumps on Dn 50 foot bracket ____ p.34-35

Srt10 2 pumps on Dn 65 foot bracket ____ p.36-37

Srt10 2 pumps on Dn 50 foot bracket
with additional valve chamber ____ p.38-39

Srt10 2 pumps on Dn 65 foot bracket
with additional valve chamber ____ p.40-41





STAR1000 Dn50 2 pumps on foot bracket



*Commissioning:
please consult us*

Height: 2.50 m
PUE25P2DN050T

Height: 2.00 m
PUE20P2DN050T

Design

- Polyethylene tank, corrosion-proof. Manufactured with reinforcements, for a better mechanical resistance.
- Useful volume under inlet level: 800 L.
- Lockable non-slip cover for a safety installation under green space.
- Female PVC entry sleeve with seal for external PVC diam. 200 tube.
- External diam. 63 PVC pressure to stick outlet tube.
- Female PVC ventilation sleeve with seal diam. 100/117 with stopper for external diam. 100 PVC tube.
- 2 TPC diam. 76/90 cable gland sheaths.
- Handling straps for an easier installation.

Internal equipment

- 2 submerged pumps,
- Composite (for stations with height 2m) or stainless steel (for stations with height 2.5m) foot brackets and guiding bars to facilitate the set up of the pumps,
- 2 PVC Dn 50 discharge pipes,
- 2 PVC ball check (non-return) valves and 2 Dn 50 PVC ball valves mounted on union,
- 1 alarm float (10m cable),
- 1 piezo probe installed on a chain with counterweight (10m cable),
- Polyethylene support to get the cage screen.

IL Star 1000,
height 2 m :
standard 1200 mm

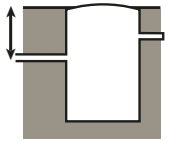

On request from
800 to 1300 mm

IL Star 1000,
height 2.5m :
standard 1700 mm

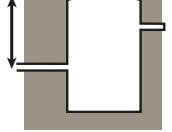

On request from
1300 to 1700 mm

Texts, dimensions, pictures and diagrams are not contractual.

Collective

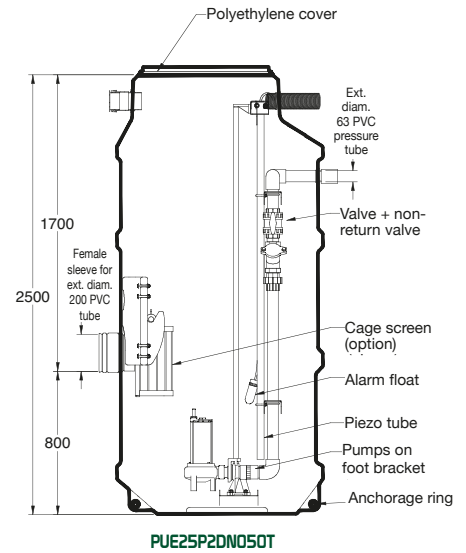
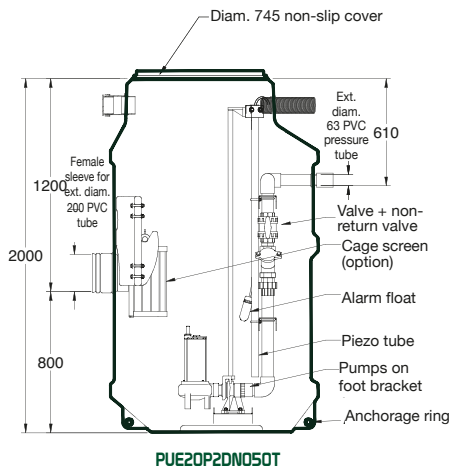
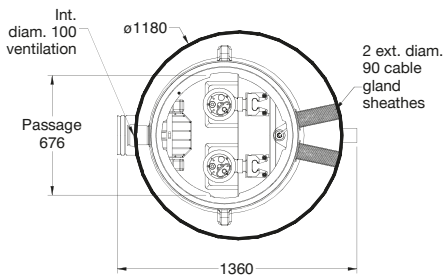

For our STAR 1000 range, the selection of your pumping station is performed in **3 steps**:

1 Selection of the tank

Reference of the tank	Diam. inlet (mm)	Diam. outlet (mm)	Weight (kg)
PUE20P2DN050T	For ext. diam. 200 PVC tube	For ext. diam. 63 PVC pressure tube	140
PUE25P2DN050T			179

2 Selection of the pump

Reference of the pump	No. curve/pump	Cross section (mm)	Intensity (amperes)	Voltage (volts)	Power (kW)	Reference of the control box
PJS0590M	17	50	10,5	Mono 230 V	1,5	CSJ209
PJS0590T			4,1	Tri 400 V		CSJ204

3 Selection of the control box

> 50 to 100 users

STAR1000 Dn50



The pumps



Single-phase 230 V with capacitor integrated to the box or three-phase 400 V.

Construction: Cast-iron pump housing and Vortex wheel, stainless steel engine cover.

Protection: Insulation class F IP68.

Liquids temperature: max + 50°C.

Usage: waste water.

Cross section: 50 mm.

Discharge: 2".

Equipped with a 10 m cable and **2 wires for Ipsotherm.**

Weight: 18.2 kg.

17

PJS0590M or T

SEMISOM 590 M or T

Model selection

depending on the rate and on the Total Head (TDH).

If you don't know them, please refer to page 45 to calculate them.

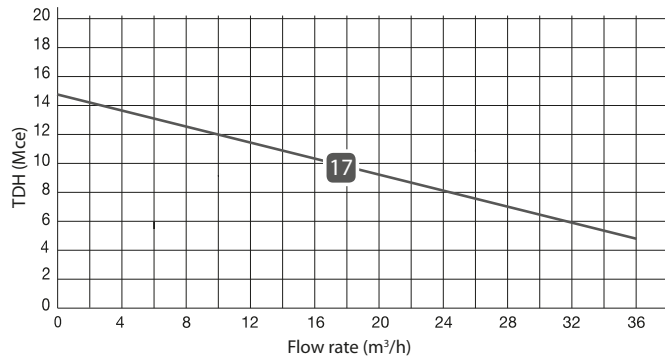

The control box and the probe



Piezo probe (10 m cable)



Technical features:

- Single-phase 230 volts or four-phase 400 volts + neutral.
- Automatic operation of the pumps depending on the tank level.
- Automatic reverse to every start.
- Audible and visual alarm on alarm float.
- Lockable disconnector.
- Forced March function of the pumps with push-button.
- For 230 V pumps: capacitors integrated to the box.
- Pump visualisation March-Disjunction.
- Dry contact for alarm report.
- **Dimensions: L 278 x D 130 x H 378 mm**

For more info, see page 46

Options

Cover extensions

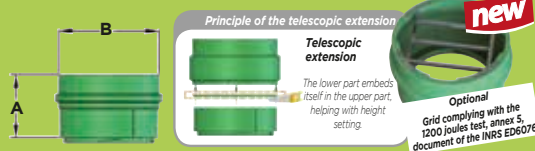

From the second embedded extension, the concrete slab is required. It is recommended that the installation is as less deep as possible to help with maintenance and to avoid ground overloads on the tank.

References	A (mm)	B (mm)	Weight (kg)	Telescopic	Safety grid
ETR47EF	490	780	10,5 kg	•	GI0670I
ETR65EF	650	780	18 kg	•	•

50 kg folding hoist arm

Complies with the 2006/42/CE Machinery Directive. Declaration of conformity upon delivery. Fitness for use to perform upon definitive installation.

OS096
new

Galvanised steel 50 kg adjustable hoist arm with winch and galvanised steel hoist arm bracket. The hoist arm is removable and can be folded for easy transportation. Weight: 17 kg.

Aluminium cage screen

With handling chain. Cage dimensions: L 245 x D 215 x H 400 mm. Weight: 2.9 k

OS530

Cabinet with base for outdoors installation

Polyester. Dimensions: L 540 x H 520 x D 240 mm + base height 580 mm.

CP510

To install a 1 or 2 pumps electrical control box.

Extension cable kit with:

- 1 connection for 2 single or three-phase pumps and 1 alarm float,
 - 1 connection for piezo probe.
- To install in a chamber or inside the station.

OS49010

for 10 m cable

OS49020

for 20 m cable

OS49030

for 30 m cable



Anchorage kit

OSE73060

4 steel items. Containing a tank bracket and a welded mesh: the kit helps with the tank anchorage in case of ground water. Weight: 11.5 kg.

Safety grid

GI0670I

Grid with stainless steel independent bars for polyethylene opening diam. 740 mm.

Complies with the 1200 joules test, annex 5, document of the INRS ED6076



Texts, dimensions, pictures and diagrams are not contractual.

Collective



STAR1000 Dn65

2 pumps on foot bracket



*Commissioning:
please consult us*



Height: 2.50 m
PUE25P2DN065T

Height: 2.00 m
PUE20P2DN065T

Design

- Polyethylene tank, corrosion-proof. Manufactured with reinforcements, for a better mechanical resistance.
- Useful volume under inlet level: 800 L.
- Lockable non-slip cover for a safety installation under green space.
- Female PVC entry sleeve with seal for external PVC diam. 200 tube.
- External diam. 75 PVC pressure to stick outlet tube.
- Female PVC ventilation sleeve with seal diam. 100/117 with stopper for external diam. 100 PVC tube.
- 2 TPC diam. 76/90 cable gland sheaths.
- Handling straps for an easier installation.

Internal equipment

- 2 submerged pumps,
- Cast iron foot brackets and stainless steel guiding bars to facilitate the set up of the pumps,
- 2 PVC Dn 65 discharge pipes,
- 2 PVC ball check (non-return) valves and 2 Dn 65 PVC ball valves mounted on union,
- 1 alarm float (10m cable),
- 1 piezo probe installed on a chain with counterweight (10m cable),
- Polyethylene support to get the cage screen.

IL Star 1000,
height 2 m:
standard 1200 mm

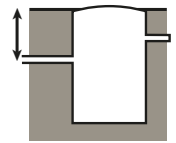

On request from
800 to 1300 mm

IL Star 1000,
height 2,5 m:
standard 1700 mm



On request from
1300 to 1700 mm

Texts, dimensions, pictures and diagrams are not contractual.

Collective

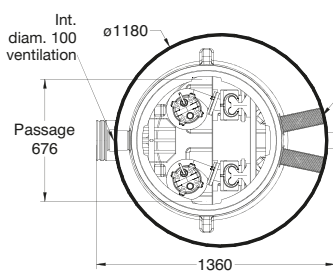

2 ext. diam. 90 cable gland sheaths

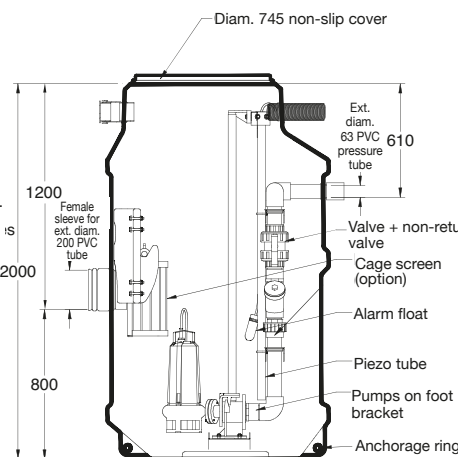

PUE20P2DN065T

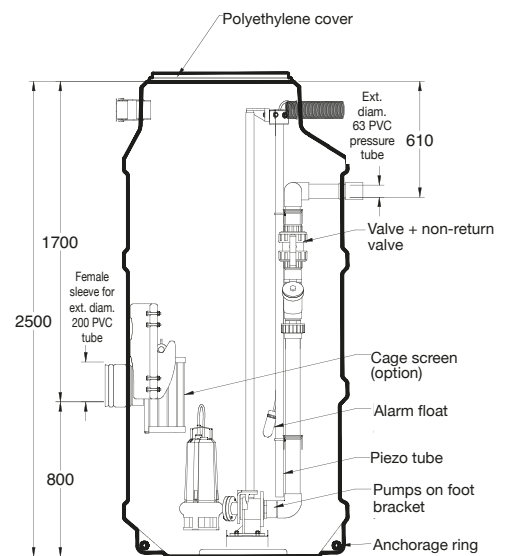

PUE25P2DN065T



For our STAR 1000 range, the selection of your pumping station is performed in **3 steps**:

1 Selection of the tank



2 Selection of the pump



3 Selection of the control box

Reference of the tank	Diam. inlet (mm)	Diam. outlet (mm)	Weight (kg)
PUE20P2DN065T	For ext. diam. 200 PVC tube	For ext. diam. 63 PVC pressure tube	168
PUE25P2DN065T			207

Reference of the pump	No. curve/pump	Cross section (mm)	Intensity (amperes)	Voltage (volts)	Power (kW)	Reference of the control box
PJS0650T	03	65	4,6	Tri 400 V	1,5	CSJ204
PJS0650HT	11	65	4,6			CSJ204
PJS1000/50T	07	50	5,9			CSJ204

PJS0650M	03	65	12	Mono 230 V	1,5	CSJ209
PJS0650HM	11	65	12			CSJ209



> 101 to 200 users

STAR1000 Dn65



The control box and the probe

Technical features:

- Single-phase 230 volts or four-phase 400 volts + neutral.
- Automatic operation of the pumps depending on the tank level.
- Automatic reverse to every start.
- Audible and visual alarm on alarm float.
- Lockable disconnecter.
- Forced March function of the pumps with push-button.
- Pump visualisation March-Disjunction.
- Dry contact for alarm report.

Dimensions:
L 278 x D 130 x H 378 mm

Piezo probe (10 m cable)



For more info, see page 46

Model selection

depending on the rate and on the Total Head (TDH).

If you don't know them, please refer to page 45 to calculate them.

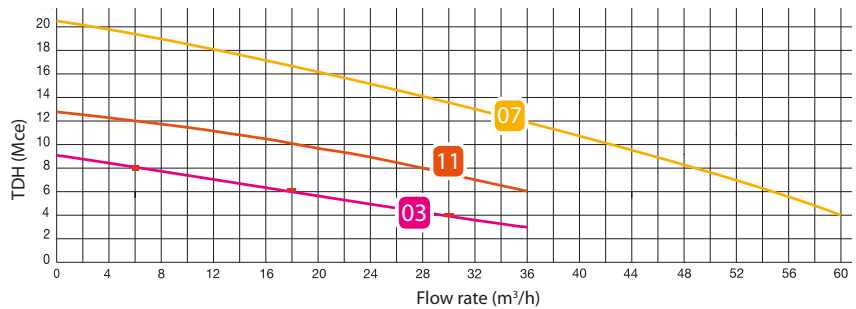

The pumps

Single-phase 230 V or three-phase 400 V.

Construction: Cast iron pump housing and steel engine cover.

Liquids temperature: max + 50°C.

Protection: Insulation class F IP68.

Usage: waste water.

Discharge: 2"1/2.

Equipped with a 10 m cable and 2 wires for Ipsotherm.



PARTICULARLY ADAPTED TO PUBLIC PLACES
NON-CLOGGING

Cast-iron Vortex wheel,
Weight: 21 kg.

03 PJS0650M or T SEMISOM 650 M or T

11 PJS0650H M or T SEMISOM 650 H M or T



Cast-iron two-channel wheel,
Weight: 39,4 kg.

07 PJS1000/50 T SEMISOM 1000/50 T

Options

Cover extensions

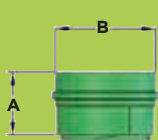

Principle of the telescopic extension

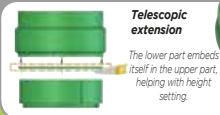

new
Optional Grid complying with the 1200 joules test, annex 5, document of the INRS ED6076

From the second embedded extension, the concrete slab is required. It is recommended that the installation is as less deep as possible to help with maintenance and to avoid ground overloads on the tank.

References	A (mm)	B (mm)	Weight (kg)	Telescopic	Safety grid
ETR47EF	490	780	10,5 kg	•	•
ETR65EF	650	780	18 kg	•	•



Aluminium cage screen

With handling chain. Cage dimensions: L 245 x D 215 x H 400 mm. Weight: 2.9 k

OS530

Extension cable kit with:

- 1 connection for 2 single or three-phase pumps and 1 alarm float,
 - 1 connection for piezo probe.
- To install in a chamber or inside the station.

OS49010 for 10 m cable

OS49020 for 20 m cable

OS49030 for 30 m cable



Anchorage kit

OSE73060

4 steel items.
Containing a tank bracket and a welded mesh: the kit helps with the tank anchorage in case of ground water.
Weight: 11,5 kg



Safety grid

G10670I

Grid with stainless steel independent bars for polyethylene opening diam. 740 mm.
Complies with the 1200 joules test, annex 5, document of the INRS ED6076



50 kg folding hoist arm



OS096

Complies with the 2006/42/CE Machinery Directive. Declaration of conformity upon delivery. Fitness for use to perform upon definitive installation.

Galvanised steel 50 kg adjustable hoist arm with winch and galvanised steel hoist arm bracket.
The hoist arm is removable and can be folded for easy transportation.
Weight: 17 kg.



Cabinet with base for outdoors installation

CP510

Polyester. Dimensions: L 540 x H 520 x D 240 mm + base height 580 mm.

To install a 1 or 2 pumps electrical control box.



STAR_{1200R} 2 pumps on foot bracket Dn50 with valve chamber



new

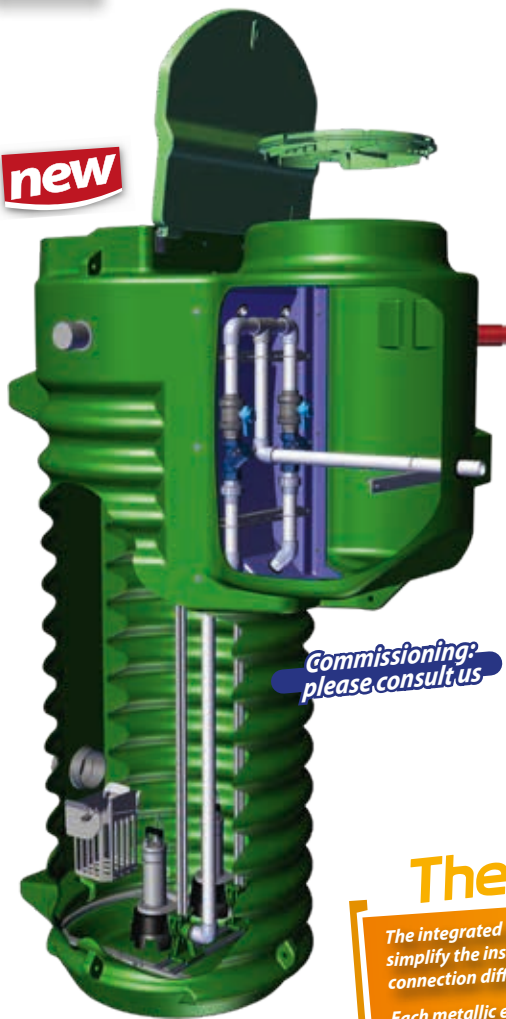

*Commissioning:
please consult us*

Design

- Polyethylene tank with high mechanical resistance, corrosion-proof.
- Integrated polyethylene valve chamber.
- Useful volume under inlet level: 875 L.
- 1 polyester lockable cover and compass-shaped articulated that maintain the opening position.
- 1 diam. 680 mm cover closure 1/4 turn locked with 1 nut for additional safety.
- Female PVC entry sleeve with seal for external PVC diam. 200 tube.
- External diam. 63 PVC pressure to stick outlet tube.
- Female PVC ventilation sleeve with seal diam. 100 with stopper.
- 2 TPC diam. 76/90 cable gland sheathes.
- Handling straps for an easier installation.

Internal equipment

- 2 submerged pumps,
- Composite foot brackets and stainless steel guiding bars to facilitate the set up of the pumps,
- 2 pump chains certified for lifting,
- 2 int. diam. 50 PVC pressure discharge pipes,
- 1 stainless steel cage screen support (for stations with heights 2m50 to 3m50),
- 1 piezo probe (10m cable) and 1 alarm float (10m cable) installed on a chain with counterweight.

The+products

The integrated valve chamber considerably simplify the installation and avoid pipes connection difficulties
Each metallic element is made in stainless steel

> Valve chamber equipment:

- 2 PVC ball check (non-return) valves and 2 Dn 50 PVC ball valves mounted on 3 pieces union,
- 1 PVC connection part.

Texts, dimensions, pictures and diagrams are not contractual.

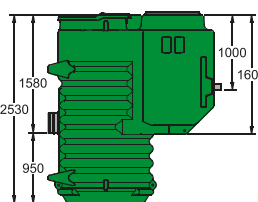
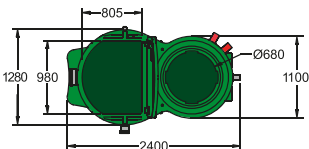

PURE25P2DN050T

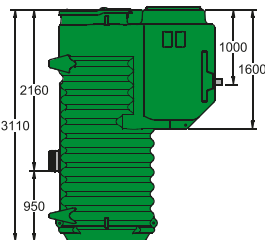

PURE30P2DN050T

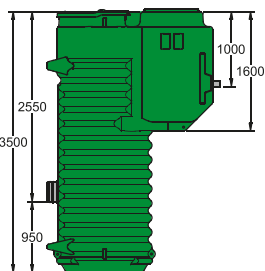

PURE35P2DN050T

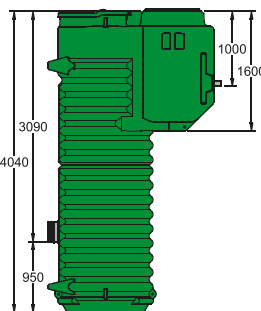

PURE40P2DN050T

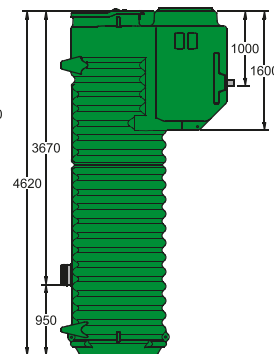

PURE45P2DN050T



For our STAR 1200R range, the selection of your pumping station is performed in **3 steps** :

1

Selection of the tank



2

Selection of the pump



3

Selection of the control box

Reference of the tank	Weight (kg)	Diam. inlet (mm)	Diam. outlet (mm)
PURE25P2DN050T	260	For ext. diam. 200 PVC tube	For ext. diam. 63 PVC pressure tube
PURE30P2DN050T	290		
PURE35P2DN050T	310		
PURE40P2DN050T	345		
PURE45P2DN050T	376		

Reference of the pump	No. curve/pump	Cross section (mm)	Intensity (amperes)	Voltage (volts)	Power (kW)	Reference of the control box
PJS0590M	17	50	10,5	Mono 230 V	1,5	CSJ209
PJS0590T			4,1	Tri 400 V		CSJ204



> 50 to 100 users

STAR1200R Dn50



The pumps



Single-phase 230 V with capacitor integrated to the box or three-phase 400 V.

Construction: Cast iron pump housing and Vortex wheel, stainless steel engine cover.

Protection: Insulation class F IP68.

Liquids temperature: max + 50°C.

Usage: waste water.

Discharge: 2".

Equipped with a 10 m cable and **2 wires for Ipsotherm.**

Weight: 18.2 kg.

Model selection

Model selection depending on the rate and on the Total Head (TDH). If you don't know them, please refer to page 45 to calculate them.

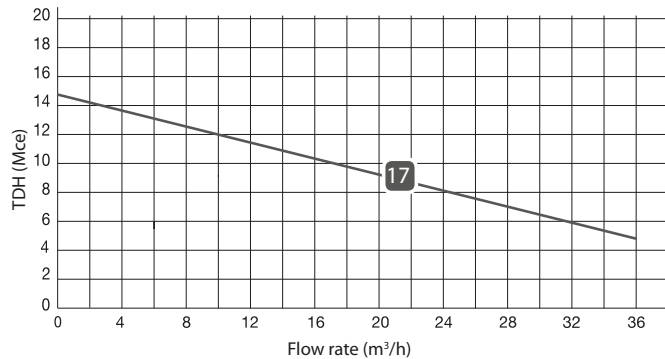

17 PJS0590M or T SEMISOM 590 M or T

The control box and the probe



Piezo probe (10 m cable)



Technical features:

- Single-phase 230 volts or four-phase 400 volts + neutral.
- Automatic operation of the pumps depending on the tank level.
- Automatic reverse to every start.
- Audible and visual alarm on alarm float.
- Lockable disconnecter.
- Forced March function of the pumps with push-button.
- Pump visualisation March-Disjunction.
- Dry contact for alarm report.
- **Dimensions: L 278 x D 130 x H 378 mm**

For more info, see page 46

Options



Aluminium cage screen on support

With handling chain.
Cage dimensions: L 245 x D 215 x H 400 mm.
Weight: 2.9 kg

OS590

For stations with height from 2.5m to 3.5m



50 kg folding hoist arm

Galvanised steel 50 kg adjustable hoist arm with winch and galvanised steel hoist arm bracket.
The hoist arm is removable and can be folded for easy transportation.
Weight: 17 kg.



Complies with the 2006/42/CE Machinery Directive. Declaration of conformity upon delivery. Fitness for use to perform upon definitive installation.

OS101



Aluminium cage screen on guiding bar

With handling chain.
Cage dimensions: L 270 x D 120 x H 400 mm.
Weight: 4.9 kg

OS595

For stations with height from 4m to 4.5m



Cabinet with base for outdoors installation

Polyester. Dimensions: L 540 x H 520 x D 240 mm + base height 580 mm.
To install a 1 or 2 pumps electrical control box.

CP510

Anchorage kit

Containing a tank bracket and a welded mesh: the kit helps with the tank anchorage in case of ground water.

2 steel items for the tank.

1 steel item for the valve chamber.

Total weight: 8.5 kg.

OSE73050

Extension cable kit with:

- 1 connection for 2 single or three-phase pumps and 1 alarm float,
 - 1 connection for piezo probe.
- To install in a chamber or inside the station.

OS49010 OS49010 for 10 m cable

OS49020 OS49020 for 20 m cable

OS49030 OS49030 for 30 m cable



Safety grid for the pumping station

This grid guarantees security during maintenance process.

With 304 stainless steel independent bars.

GIE121

Complies with the 1200 joules test, annex 5, document of the INRS ED6076



Texts, dimensions, pictures and diagrams are not contractual.

Collective



STAR1200R Dn65 with valve chamber



new

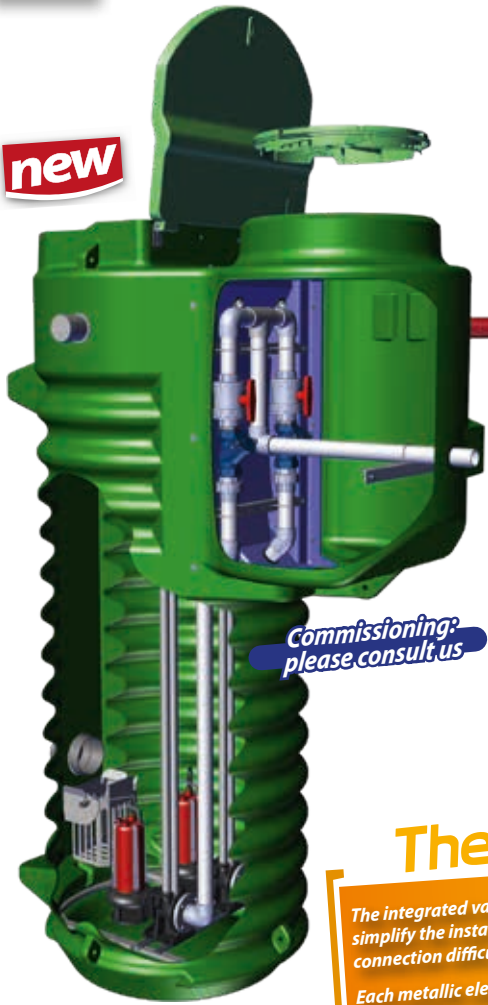

*Commissioning:
please consult us*

The+products

*The integrated valve chamber considerably simplify the installation and avoid pipes connection difficulties
Each metallic element is made in stainless steel*

Design

- Polyethylene tank with high mechanical resistance, corrosion-proof.
- Integrated polyethylene valve chamber.
- Useful volume under inlet level: 875 L.
- 1 polyester lockable cover and compass-shaped articulated that maintain the opening position.
- 1 diam. 680 mm cover closure 1/4 turn locked with 1 nut for additional safety.
- Female PVC entry sleeve with seal for external PVC diam. 200 tube.
- External diam. 75 PVC pressure to stick outlet tube.
- Female PVC ventilation sleeve with seal diam. 100 with stopper.
- 2 TPC diam. 76/90 cable gland sheathes.
- Handling straps for an easier installation.

Internal equipment

- 2 submerged pumps,
- Cast iron foot brackets and stainless steel guiding bars to facilitate the set up of the pumps,
- 2 pump chains certified for lifting,
- 2 int. diam. 63 PVC pressure discharge pipes,
- 1 stainless steel cage screen support (for stations with heights 2m50 to 3m50),
- 1 piezo probe (10m cable) and 1 alarm float (10m cable) installed on a chain with counterweight.

> Valve chamber equipment:

- 2 PVC ball check (non-return) valves and 2 Dn 65 PVC ball valves mounted on 3 pieces union,
- 1 PVC connection part.

Texts, dimensions, pictures and diagrams are not contractual.

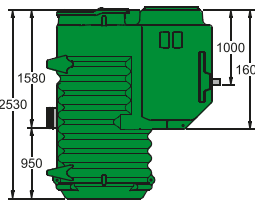
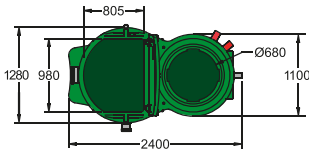

PURE25P2DN065T

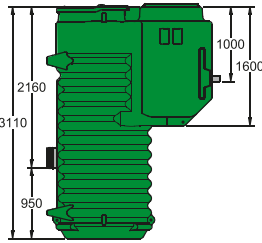

PURE30P2DN065T

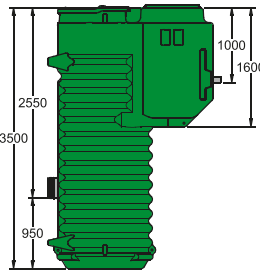

PURE35P2DN065T

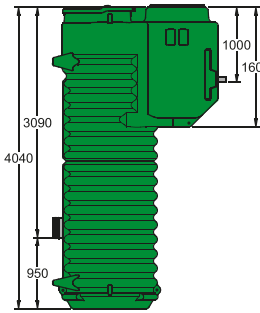

PURE40P2DN065T

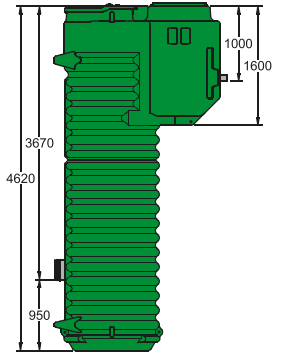

PURE45P2DN065T



For our STAR 1200R range, the selection of your pumping station is performed in **3 steps**:

1

Selection of the tank



2

Selection of the pump



3

Selection of the control box

Reference of the tank	Weight (kg)	Diam. inlet (mm)	Diam. outlet (mm)
PURE25P2DN065T	283	For ext. diam. 200 PVC tube	For ext. diam. 63 PVC pressure tube
PURE30P2DN065T	314		
PURE35P2DN065T	336		
PURE40P2DN065T	373		
PURE45P2DN065T	403		

Reference of the pump	No. curve/pump	Cross section (mm)	Intensity (amperes)	Voltage (volts)	Power (kW)	Reference of the control box
PJS0650T	03	65	4,6	Tri 400 V	1,5	CSJ204
PJS0650HT	11	65	4,6			CSJ204
PJS1000/50T	07	50	5,9			CSJ204
PJS0650M	03	65	12	Mono 230 V	1,5	CSJ209
PJS0650HM	11	65	12			CSJ209



> 101 to 200 users

STAR1200R Dn65



The control box and the probe

Technical features:

- Single-phase 230 volts or four-phase 400 volts + neutral.
 - Automatic operation of the pumps depending on the tank level.
 - Automatic reverse to every start.
 - Audible and visual alarm on alarm float.
 - Lockable disconnecter.
 - Forced March function of the pumps with push-button.
 - Pump visualisation March-Disjunction.
 - Dry contact for alarm report.
- Dimensions:**
L 278 x D 130 x H 378 mm



For more info, see page 46

Model selection

depending on the rate and on the Total Head (TDH). If you don't know them, please refer to page 45 to calculate them.

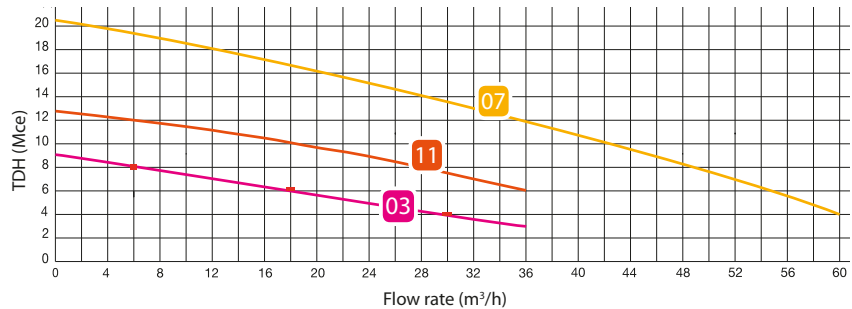

The pumps

Single-phase 230 V or three-phase 400 V.

Construction: Cast iron pump housing and steel engine cover.

Liquids temperature: max + 50°C.

Protection: Insulation class F IP68.

Usage: waste water.

Discharge: 2"1/2.

Equipped with a 10 m cable and 2 wires for Ipsotherm.



PARTICULARLY ADAPTED TO PUBLIC PLACES
NON-CLOGGING

Cast-iron Vortex wheel,
Weight: 21 kg.

- 03** PJS0650M or T SEMISOM 650 M or T
- 11** PJS0650 H M or T SEMISOM 650 H M or T



Cast-iron two-channel wheel,
Weight: 39.4 kg.

- 07** PJS1000/50 T SEMISOM 1000/50 T

Options



Aluminium cage screen on support

With handling chain.
Cage dimensions:
L 245 x D 215 x H 400 mm.
Weight: 2.9 kg

OS590

For stations with height from 2.5m to 3.5m



50 kg folding hoist arm

Galvanised steel 50 kg adjustable hoist arm with winch and galvanised steel hoist arm bracket.
The hoist arm is removable and can be folded for easy transportation.
Weight: 17 kg.

Complies with the 2006/42/CE Machinery Directive. Declaration of conformity upon delivery. Fitness for use to perform upon definitive installation.

OS101



Aluminium cage screen on guiding bar

With handling chain.
Cage dimensions:
L 270 x D 120 x H 400 mm.
Weight: 4.9 kg

OS595

For stations with height from 4m to 4.5m



Cabinet with base for outdoors installation

Polyester. Dimensions: L 540 x H 520 x D 240 mm + base height 580 mm.
To install a 1 or 2 pumps electrical control box.

CP510

Anchorage kit

OSE73050

Containing a tank bracket and a welded mesh: the kit helps with the tank anchorage in case of ground water.
2 steel items for the tank.
1 steel item for the valve chamber.
Total weight: 8.5 kg.

Extension cable kit with:

- 1 connection for 2 single or three-phase pumps and 1 alarm float,
 - 1 connection for piezo probe.
- To install in a chamber or inside the station.

- OS49010** OS49010 for 10 m cable
- OS49020** OS49020 for 20 m cable
- OS49030** OS49030 for 30 m cable



Safety grid for the pumping station

GIE121

This grid guarantees security during maintenance process.
With 304 stainless steel independent bars.
Complies with the 1200 joules test, annex 5, document of the INRS ED6076

Texts, dimensions, pictures and diagrams are not contractual.

Collective



SRT10 2 pumps on foot bracket Dn50



Model shown
PUP30P2DN050T

Design

- Polyester tank with high mechanical resistance, corrosion-proof.
- Useful volume under inlet level: 628 L.
- 1 polyethylene half-moon shaped base with wide opening for a perfect accessibility.
- 1 polyester lockable cover for a safety installation under green space.
- External diam. 200 PVC inlet tube - supplied with flexible adaptation sleeve.
- External diam. 63 PVC pressure to stick outlet tube.
- Female PVC ventilation sleeve with seal diam. 100/117 with stopper for external diam. 100 PVC tube.
- 2 TPC diam. 76/90 cable gland sheaths.
- Handling and anchorage straps for an easier installation.
- Other dimensions on request: please consult our design office.

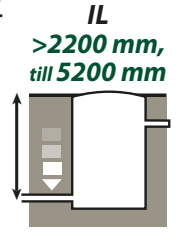

**Commissioning:
please consult us**

Internal equipment

- 2 submerged pumps,
- Composite foot brackets and stainless steel guiding bars to facilitate the set up of the pumps,
- 2 diam. 50 PVC discharge pipes,
- 2 PVC ball check (non-return) valves and 2 Dn 50 PVC ball valves mounted on union,
- 1 stainless steel cage screen support (for stations with heights ≤ 3m50),
- 1 alarm float (10m cable),
- 1 piezo probe (10m cable) installed on a chain with counterweight.

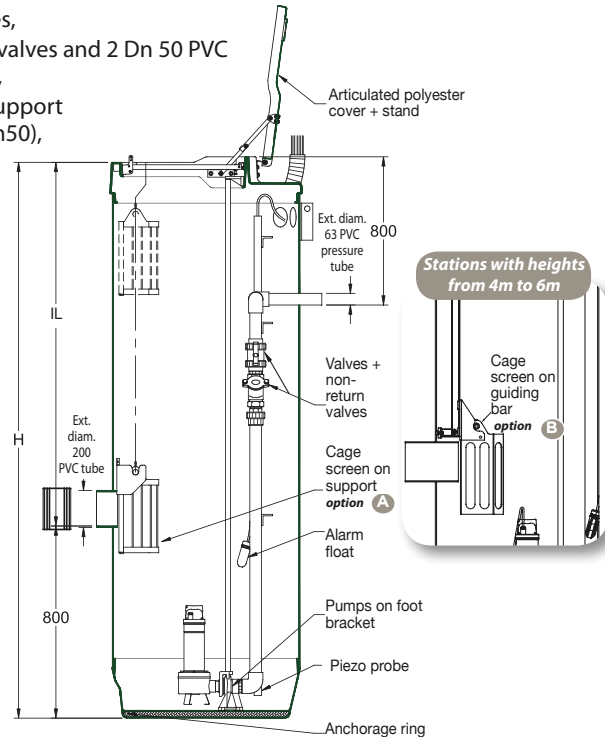

Stations with heights from 4m to 6m

Collective

Texts, dimensions, pictures and diagrams are not contractual.



The+product
Half-moon shaped base with wide opening for a complete accessibility.

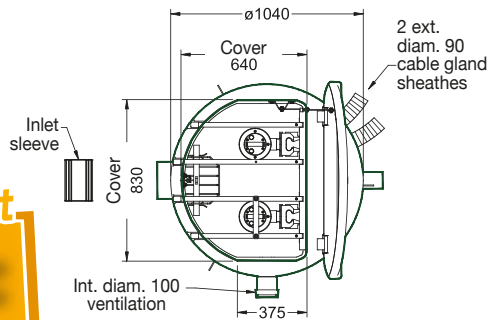

For our SRT 10 range, the selection of your pumping station is performed in **3 steps**:

1

Selection of the tank

+

2

Selection of the pump

+

3

Selection of the control box

Reference of the tank	H (height in mm)	Weight (in kg)	IL (in mm)	Diam. inlet (mm)	Diam. outlet (mm)
PUP30P2DN050T	3000	198	2200	Ext. diam. 200 PVC tube	Ext. diam. 63 PVC pressure tube
PUP35P2DN050T	3500	216	2700		
PUP40P2DN050T	4000	234	3200		
PUP45P2DN050T	4500	251	3700		
PUP50P2DN050T	5000	269	4200		
PUP55P2DN050T	5500	287	4700		
PUP60P2DN050T	6000	305	5200		

Reference of the pump	No. curve/pump	Cross section (mm)	Intensity (amperes)	Voltage (volts)	Power (kW)	Reference of the control box
PJS0590M	17	50	10,5	Mono 230 V	1,5	CSJ209
PJS0590T			4,1	Tri 400 V		CSJ204

Other Inlet Levels (IL) on request: please consult our design office.

> 50 to 100 users

SRT10 Dn50



The pumps



Single-phase 230 V with capacitor integrated to the box or three-phase 400 V.

Construction: Cast iron pump housing and Vortex wheel, stainless steel engine cover.

Protection: Insulation class F IP68.

Liquids temperature: max + 50°C.

Usage: waste water.

Discharge: 2".

Equipped with a 10 m cable and 2 wires for Ipsotherm.

Weight: 18.2 kg.

17

PJS0590M or T

SEMISOM 590 M or T

Model selection

depending on the rate and on the Total Head (TDH).

If you don't know them, please refer to page 45 to calculate them.

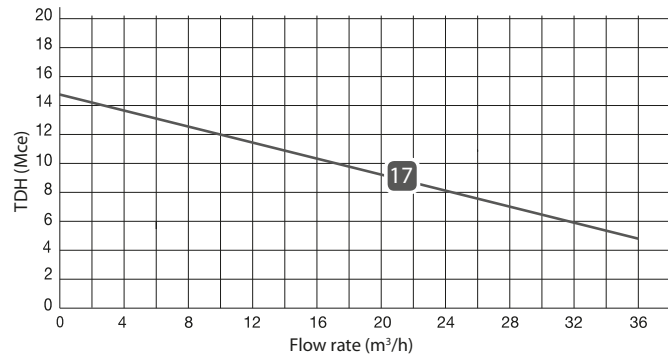

The control box and the probe



Piezo probe (10 m cable)



Technical features:

- Single-phase 230 volts or four-phase 400 volts + neutral.
- Automatic operation of the pumps depending on the tank level.
- Automatic reverse to every start.
- Audible and visual alarm on alarm float.
- Lockable disconnecter.
- Forced March function of the pumps with push-button.
- Pump visualisation March-Disjunction.
- Dry contact for alarm report.
- **Dimensions:** L 278 x D 130 x H 378 mm

Options



Aluminium cage screen on support ^A

OS535

For stations with height from 3m to 3.5m. With handling chain. Cage dimensions: L 245 x D 215 x H 400 mm. Weight: 2.9 kg



50 kg folding hoist arm



Complies with the 2006/42/CE Machinery Directive. Declaration of conformity upon delivery. Fitness for use to perform upon definitive installation.

Galvanised steel 50 kg adjustable hoist arm with winch and galvanised steel hoist arm bracket. The hoist arm is removable and can be folded for easy transportation. Weight: 17 kg.

OS101



Aluminium cage screen on guiding bar ^B

With handling chain. Cage dimensions: L 280 x D 120 x H 400 mm. Weight: 4.9 kg

DS2001050A

For stations with height from 4m to 5m ...

DS2001070A

For stations with height from 5m to 6m ...



Cabinet with base for outdoors installation

CP510

Polyester. Dimensions: L 540 x H 520 x D 240 mm + base height 580 mm. To install a 1 or 2 pumps electrical control box.

Anchorage kit

Containing a tank bracket and a welded mesh: the kit helps with the tank anchorage in case of ground water.

3 steel items for the pumping station.

Total weight: 8.5 kg.

OSE73050

Extension cable kit with:

- 1 connection for 2 single or three-phase pumps and 1 alarm float,
 - 1 connection for piezo probe.
- To install in a chamber or inside the station.

OS49010 for 10 m cable

OS49020 for 20 m cable

OS49030 for 30 m cable



Safety grid

GIB101

This grid guarantees security during maintenance process. With 304 stainless steel independent bars.



Complies with the 1200 joules test, annex 5, document of the INRS ED6076

Texts, dimensions, pictures and diagrams are not contractual.

Collective



SRT10 2 pumps on foot bracket Dn65



Design

- Polyester tank with high mechanical resistance, corrosion-proof.
- Useful volume under inlet level: 628 L.
- 1 polyethylene half-moon shaped base with wide opening for a perfect accessibility.
- 1 polyester lockable cover for a safety installation under green space.
- External diam. 200 PVC inlet tube - supplied with flexible adaptation sleeve.
- External diam. 75 PVC pressure to stick outlet tube.
- Female PVC ventilation sleeve with seal diam. 100/117 with stopper for external diam. 100 PVC tube.
- 2 TPC diam. 76/90 cable gland sheathes.
- Handling and anchorage straps for an easier installation.
- Other dimensions on request: please consult our design office.

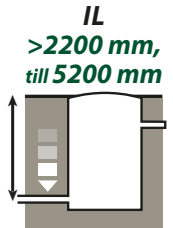

**Commissioning:
please consult us**

Internal equipment

- 2 submerged pumps,
- Cast iron foot brackets and stainless steel guiding bars to facilitate the set up of the pumps,
- 2 diam. 65 PVC discharge pipes,
- 2 PVC ball check (non-return) valves and 2 Dn 65 PVC ball valves mounted on union,
- 1 stainless steel cage screen support (for stations with heights $\leq 3m50$),
- 1 alarm float (10m cable),
- 1 piezo probe (10m cable) installed on a chain with counterweight.



Model shown
PUP30P2DN065T



The+product
Half-moon shaped base with wide opening for a complete accessibility.

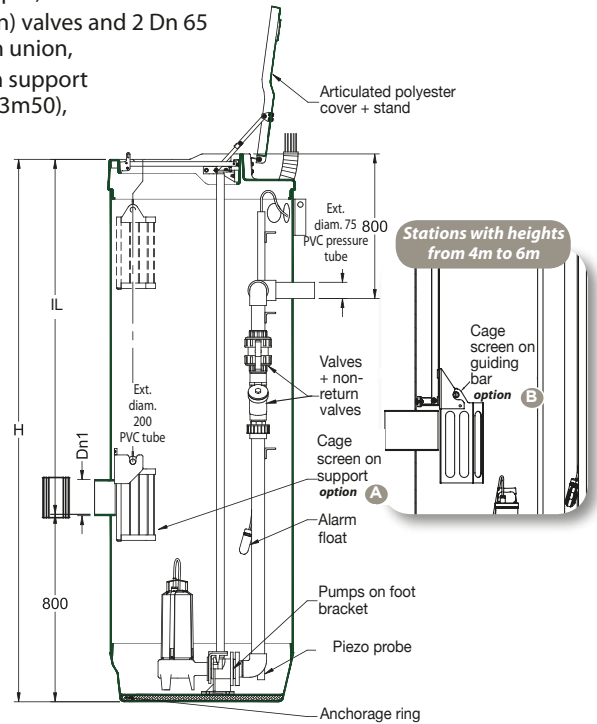
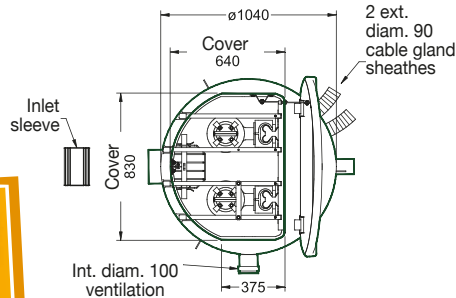

Texts, dimensions, pictures and diagrams are not contractual.



For our SRT 10 range, the selection of your pumping station is performed in **3 steps**:

1

Selection of the tank



2

Selection of the pump



3

Selection of the control box

Reference of the tank	H (height in mm)	Weight (in kg)	IL (in mm)	Diam. inlet (mm)	Diam. outlet (mm)
PUP30P2DN065T	3000	251	2200	Ext. diam. 200 PVC tube	Ext. diam. 75 PVC pressure tube
PUP35P2DN065T	3500	269	2700		
PUP40P2DN065T	4000	286	3200		
PUP45P2DN065T	4500	304	3700		
PUP50P2DN065T	5000	322	4200		
PUP55P2DN065T	5500	340	4700		
PUP60P2DN065T	6000	358	5200		

Reference of the pump	No. curve/pump	Cross section (mm)	Intensity (amperes)	Voltage (volts)	Power (kW)	Reference of the control box
PJS0650T	03	65	4,6	Tri 400 V	1,5	CSJ204
PJS0650HT	11	65	4,6			
PJS1000/50T	07	50	5,9			
PJS0650M	03	65	12	Mono 230 V	1,5	CSJ209
PJS0650HM	11	65	12			

Other Inlet Levels (IL) on request: please consult our design office.

> 101 to 200 users

SRT10 Dn65



The control box and the probe

Technical features:

- Single-phase 230 volts or four-phase 400 volts + neutral.
- Automatic operation of the pumps depending on the tank level.
- Automatic reverse to every start.
- Audible and visual alarm on alarm float.
- Lockable disconnecter.
- Forced March function of the pumps with push-button.
- Pump visualisation March-Disjunction.
- Dry contact for alarm report.

Dimensions:
L 278 x D 130 x H 378 mm

Piezo probe
(10 m cable)



> For more info, see page 46

Model selection

depending on the rate and on the Total Head (TDH).
If you don't know them, please refer to page 45 to calculate them.

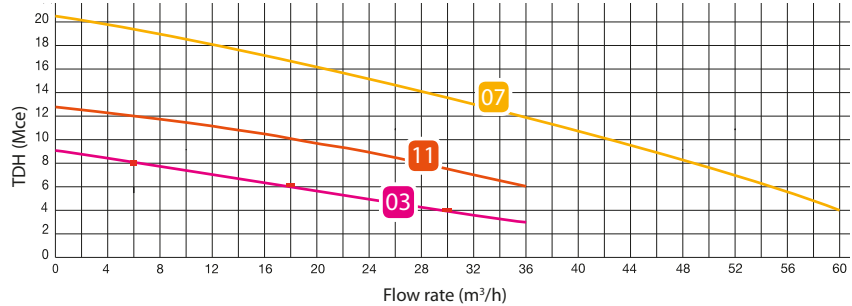

The pumps

Single-phase 230 V or three-phase 400 V.

Construction: Cast iron pump housing and steel engine cover.

Liquids temperature: max + 50°C.

Protection: Insulation class F IP68.

Usage: waste water.

Discharge: 2"1/2.

Equipped with a 10 m cable and 2 wires for Ipsotherm.



PARTICULARLY ADAPTED TO PUBLIC PLACES
NON-CLOGGING

Cast-iron Vortex wheel,
Weight: 21 kg.

03 PJS0650M or T SEMISOM 650 M or T

11 PJS0650 H M or T SEMISOM 650 H M or T



Cast-iron two-channel wheel,
Weight: 39.4 kg.

07 PJS1000/50 T SEMISOM 1000/50 T

Options



Aluminium cage screen on support ^A

OS535

For stations with height from 3m to 3.5m.
With handling chain.
Cage dimensions: L 245 x D 215 x H 400 mm.
Weight: 2.9 kg



50 kg folding hoist arm



Complies with the 2006/42/CE Machinery Directive. Declaration of conformity upon delivery. Fitness for use to perform upon definitive installation.

Galvanised steel 50 kg adjustable hoist arm with winch and galvanised steel hoist arm bracket.
The hoist arm is removable and can be folded for easy transportation.
Weight: 17 kg.

OS101



Aluminium cage screen on guiding bar ^B

With handling chain.
Cage dimensions:
L 280 x D 120 x H 400 mm. Weight: 4.9 kg

For stations with height from 4m to 5m **DS2001050A**

For stations with height from 5m to 6m **DS2001070A**



Cabinet with base for outdoors installation

CP510

Polyester. Dimensions: L 540 x H 520 x D 240 mm + base height 580 mm.
To install a 1 or 2 pumps electrical control box.

Anchorage kit

Containing a tank bracket and a welded mesh: the kit helps with the tank anchorage in case of ground water.

3 steel items **for the pumping station.**

OSE73050

Total weight: 8.5 kg.

Extension cable kit with:

- 1 connection for 2 single or three-phase pumps and 1 alarm float,
- 1 connection for piezo probe.
To install in a chamber or inside the station.

OS49010 for 10 m cable

OS49020 for 20 m cable

OS49030 for 30 m cable



Safety grid

GIB101

This grid guarantees security during maintenance process. With 304 stainless steel independent bars.

Complies with the 1200 joules test, annex 5, document of the INRS ED6076



Texts, dimensions, pictures and diagrams are not contractual.

Collective



SRT10 2 pumps on foot bracket Dn50 with valve chamber



IL
>2200 mm,
till 5200 mm



The+product

*Easier maintenance:
Through the chamber, direct
access to the valves and
non-return valves of the station.*

Design

- Polyester tank and valve chamber with high mechanical resistance, corrosion-proof.
- Useful volume under inlet level: 628 L.
- Polyethylene half-moon shaped base for the pumping station; polyester base for the valve chamber.
- 2 polyester lockable covers for a safety installation under green space.
- External diam. 200 PVC inlet tube - supplied with flexible adaptation sleeve.
- External diam. 63 PVC pressure to stick outlet tube.
- Female PVC ventilation sleeve with seal diam. 100/117 with stopper for external diam. 100 PVC tube.
- 2 TPC diam. 76/90 cable gland sheaths.
- Handling and anchorage straps for an easier installation.
- Other dimensions on request: please consult our design office.

**Commissioning:
please consult us**

Model shown
PURP30P2DN050T

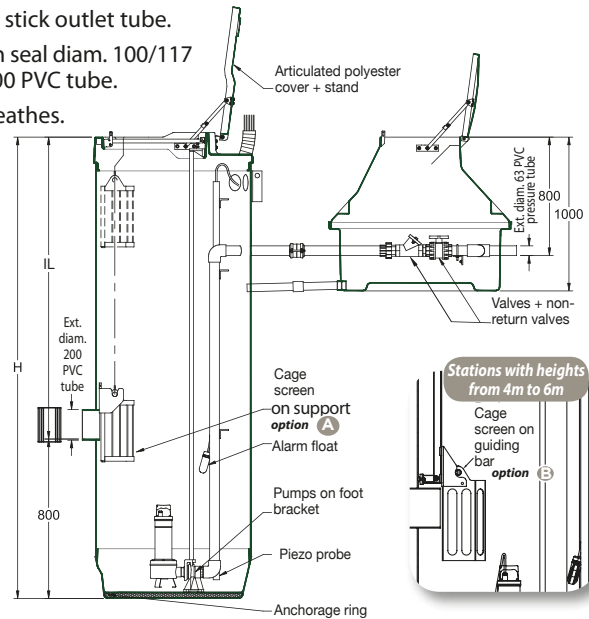
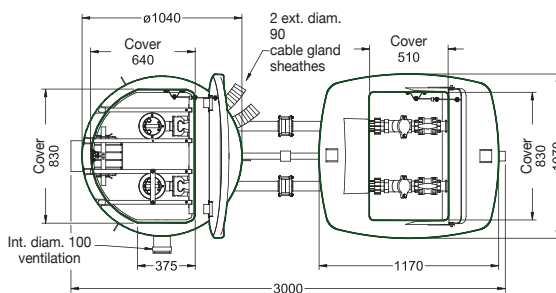

For our SRT 10 range, the selection of your pumping station is performed in 3 steps:

- 1 Selection of the tank**
- 2 Selection of the pump**
- 3 Selection of the control box**

Reference of the tank	H (height in mm)	Weight (in kg)	IL (in mm)	Diam. inlet (mm)	Diam. outlet (mm)
PURP30P2DN050T	3000	198	2200	Ext. diam. 200 PVC tube	Ext. diam. 63 PVC pressure tube
PURP35P2DN050T	3500	216	2700		
PURP40P2DN050T	4000	234	3200		
PURP45P2DN050T	4500	251	3700		
PURP50P2DN050T	5000	269	4200		
PURP55P2DN050T	5500	287	4700		
PURP60P2DN050T	6000	305	5200		

Reference of the pump	No. curve/pump	Cross section (mm)	Intensity (amperes)	Voltage (volts)	Power (kW)	Reference of the control box
PJS0590M	17	50	10,5	Mono 230 V	1,5	CSJ209
PJS0590T			4,1	Tri 400 V		CSJ204

Other Inlet Levels (IL) on request: please consult our design office.

> 50 to 100 users

SRT10 + chamber
Dn50



The pumps



Single-phase 230 V with capacitor integrated to the box or three-phase 400 V.

Construction: Cast iron pump housing and Vortex wheel, stainless steel engine cover.

Protection: Insulation class F IP68. Liquids temperature: max + 50°C.

Usage: waste water.

Discharge: 2".
Equipped with a 10 m cable and **2 wires for Ipsotherm.**

Weight: 18.2 kg.

Model selection

depending on the rate and on the Total Head (TDH).

If you don't know them, please refer to page 45 to calculate them.

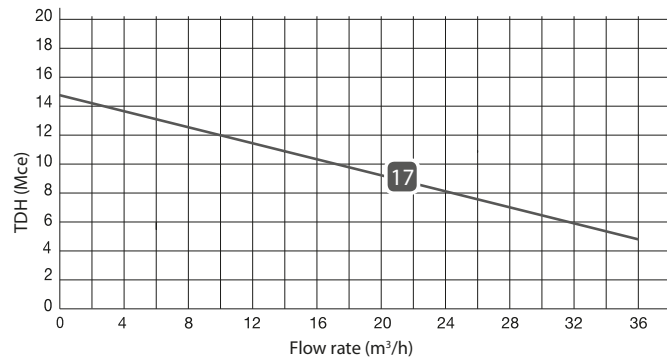

17 PJS0590M or T SEMISOM 590 M or T

The control box and the probe



Piezo probe (10 m cable)



Technical features:

- **Single-phase 230 volts or four-phase 400 volts + neutral.**
- Automatic operation of the pumps depending on the tank level.
- Automatic reverse to every start.
- Audible and visual alarm on alarm float.
- Lockable disconnecter.
- Forced March function of the pumps with push-button.
- Pump visualisation March-Disjunction.
- Dry contact for alarm report.
- **Dimensions:**
L 278 x D 130 x H 378 mm

For more info, see page 46

Options



Aluminium cage screen on support **A**

For stations with height from 3m to 3.5m. With handling chain.
Cage dimensions: L 245 x D 215 x H 400 mm.
Weight: 2.9 kg

OS535



50 kg folding hoist arm

Galvanised steel 50 kg adjustable hoist arm with winch and galvanised steel hoist arm bracket. The hoist arm is removable and can be folded for easy transportation.
Weight: 17 kg.

Complies with the 2006/42/CE Machinery Directive. Declaration of conformity upon delivery. Fitness for use to perform upon definitive installation.

OS101



Aluminium cage screen on guiding bar **B**

With handling chain.
Cage dimensions:
L 280 x D 120 x H 400 mm. Weight: 4.9 kg
For stations with height from 4m to 5m
For stations with height from 5m to 6m

DS2001050A

DS2001070A



Cabinet with base for outdoors installation

Polyester. Dimensions: L 540 x H 520 x D 240 mm + base height 580 mm.
To install a 1 or 2 pumps electrical control box.

CP510

Anchorage kit

Containing a tank bracket and a welded mesh: the kit helps with the tank anchorage in case of ground water.

For the pumping station

3 steel items.
Weight: 8.5 kg.

OSE73050

For the valve chamber

4 steel items.
Weight: 11.5 kg.

OSE73060

Extension cable kit with:

- 1 connection for 2 single or three-phase pumps and 1 alarm float,
 - 1 connection for piezo probe.
- To install in a chamber or inside the station.

OS49010 for 10 m cable

OS49020 for 20 m cable

OS49030 for 30 m cable



Safety grid for the pumping station

This grid guarantees security during maintenance process. With 304 stainless steel independent bars.

Complies with the 1200 joules test, annex 5, document of the INRS ED6076

GIB101



Texts, dimensions, pictures and diagrams are not contractual.

Collective



SRT10 2 pumps on foot bracket Dn65 with valve chamber



IL
>2200 mm,
till 5200 mm



The+product

*Easier maintenance:
Through the chamber, direct
access to the valves and
non-return valves of the station.*

*Commissioning?
please consult us*

Model shown
PURP30P2DN065T

Design

- Polyester tank and valve chamber with high mechanical resistance, corrosion-proof.
- Useful volume under inlet level: 628 L.
- Polyethylene half-moon shaped base for the pumping station ; polyester base for the valve chamber.
- 2 polyester lockable covers for a safety installation under green space.
- External diam. 200 PVC inlet tube - supplied with flexible adaptation sleeve.
- External diam. 75 PVC pressure to stick outlet tube.
- Female PVC ventilation sleeve with seal diam. 100/117 with stopper for external diam. 100 PVC tube.
- 2 TPC diam. 76/90 cable gland sheathes.
- Handling and anchorage straps for an easier installation.
- Other dimensions on request: please consult our design office

Internal equipment

> For the pumping station:

- 2 submerged pumps,
- Cast-iron foot brackets and stainless steel guiding bars to facilitate the set up of the pumps,
- 2 diam. 65 PVC discharge pipes,
- 1 stainless steel cage screen support (for stations with heights ≤ 3m50),
- 1 alarm float (10m cable),
- 1 piezo probe (10m cable) installed on a chain with counterweight.

> For the valve chamber:

- 2 cast-iron connection-adaptor,
- 1 valve chamber / pumping station dripping return pipe,
- 2 PVC ball check (non-return) valves and 2 Dn 65 PVC ball valves mounted on union,
- 1 PVC connection part.

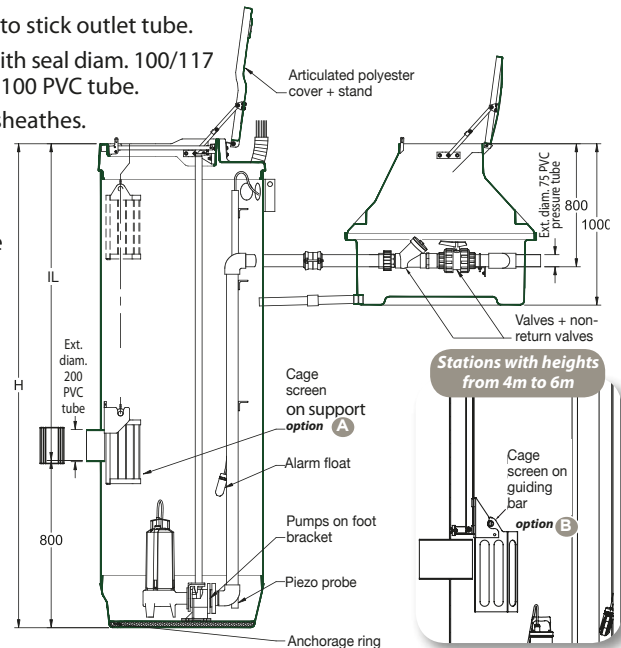
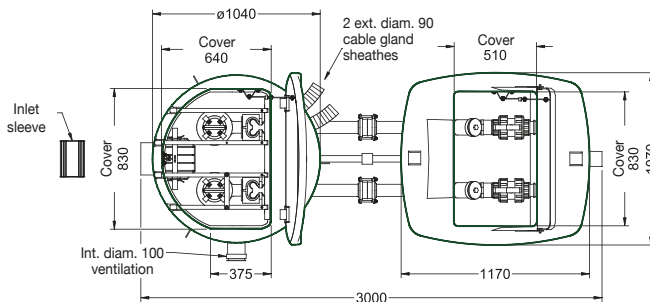

Texts, dimensions, pictures and diagrams are not contractual.

For our SRT 10 range, the selection of your pumping station is performed in 3 steps:

1 Selection of the tank



2 Selection of the pump



3 Selection of the control box

Reference of the tank	H (height in mm)	Weight (in kg)	IL (in mm)	Diam. inlet (mm)	Diam. outlet (mm)
PURP30P2DN065T	3000	251	2200	Ext. diam. 200 PVC tube	Ext. diam. 75 PVC pressure tube
PURP35P2DN065T	3500	269	2700		
PURP40P2DN065T	4000	286	3200		
PURP45P2DN065T	4500	304	3700		
PURP50P2DN065T	5000	322	4200		
PURP55P2DN065T	5500	340	4700		
PURP60P2DN065T	6000	358	5200		

Reference of the pump	No. curve/pump	Cross section (mm)	Intensity (amperes)	Voltage (volts)	Power (kW)	Reference of the control box
PJS0650T	03	65	4,6	Tri 400 V	1,5	CSJ204
PJS0650HT	11	65	4,6			
PJS1000/50T	07	50	5,9			
PJS0650M	03	65	12	Mono 230 V	1,5	CSJ209
PJS0650HM	11	65	12			

Other Inlet Levels (IL) on request: please consult our design office.

> 101 to 200 users

SRT10 + chamber



The control box and the probe

Technical features:

- Single-phase 230 volts or four-phase 400 volts + neutral.
- Automatic operation of the pumps depending on the tank level.
- Automatic reverse to every start.
- Audible and visual alarm on alarm float.
- Lockable disconnecter.
- Forced March function of the pumps with push-button.
- Pump visualisation March-Disjunction.
- Dry contact for alarm report.

Dimensions:
L 278 x D 130 x H 378 mm

Piezo probe (10 m cable)



For more info, see page 46

Model selection

depending on the rate and on the Total Head (TDH). If you don't know them, please refer to page 45 to calculate them.

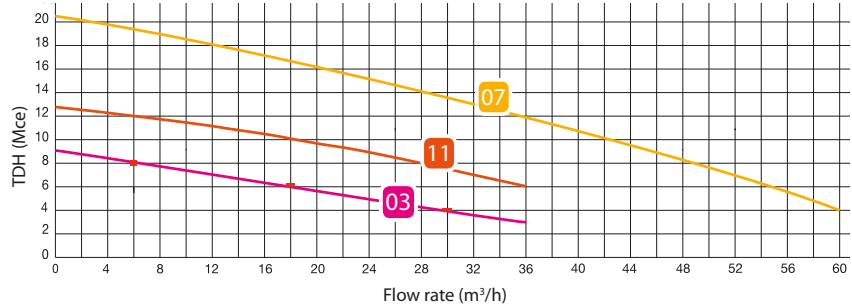

The pumps

Single-phase 230 V or three-phase 400 V.

Construction:
cast iron pump housing and steel engine cover,

Liquids temperature:
max +50°C,

Protection: insulation class F IP68,

Usage: waste water,

Discharge: 2" 1/2,

Equipped with a 10 m cable and 2 wires for Ipsotherm.



03 PJS0650M or T SEMISOM 650 M or T

11 PJS0650H M or T SEMISOM 650 H M or T

PARTICULARLY ADAPTED TO PUBLIC PLACES
NON-CLOGGING

Cast-iron Vortex wheel,
Weight: 21 kg.



07 PJS1000/50 T SEMISOM 1000/50 T

Cast-iron two-channel wheel,
Weight: 39.4kg.

Options



Aluminium cage screen on support

OS535

For stations with height from 3m to 3.5m. With handling chain. Cage dimensions: L 245 x D 215 x H 400 mm. Weight: 2.9 kg



50 kg folding hoist arm



Complies with the 2006/42/CE Machinery Directive. Declaration of conformity upon delivery. Fitness for use to perform upon definitive installation.

new

Galvanised steel 50 kg adjustable hoist arm with winch and galvanised steel hoist arm bracket. The hoist arm is removable and can be folded for easy transportation. Weight: 17 kg.

OS101



Aluminium cage screen on guiding bar

With handling chain. Cage dimensions: L 280 x D 120 x H 400 mm. Weight: 4.9 kg

For stations with height from 4m to 5m DS2001050A

For stations with height from 5m to 6m DS2001070A



Cabinet with base for outdoors installation

CP510

Polyester. Dimensions: L 540 x H 520 x D 240 mm + base height 580 mm. To install a 1 or 2 pumps electrical control box.

Anchorage kit

Containing a tank bracket and a welded mesh: the kit helps with the tank anchorage in case of ground water.

Extension cable kit with:

- 1 connection for 2 single or three-phase pumps and 1 alarm float,
 - 1 connection for piezo probe.
- To install in a chamber or inside the station.

OS49010 for 10 m cable

OS49020 for 20 m cable

OS49030 for 30 m cable



For the pumping station

3 steel items. Weight: 8.5 kg.

OSE73050

For the valve chamber

4 steel items. Weight: 11.5 kg.

OSE73060



Safety grid for the pumping station

This grid guarantees security during maintenance process. With 304 stainless steel independent bars.

Complies with the 1200 joules test, annex 5, document of the INRS ED6076

GIB101

Texts, dimensions, pictures and diagrams are not contractual.

Collective

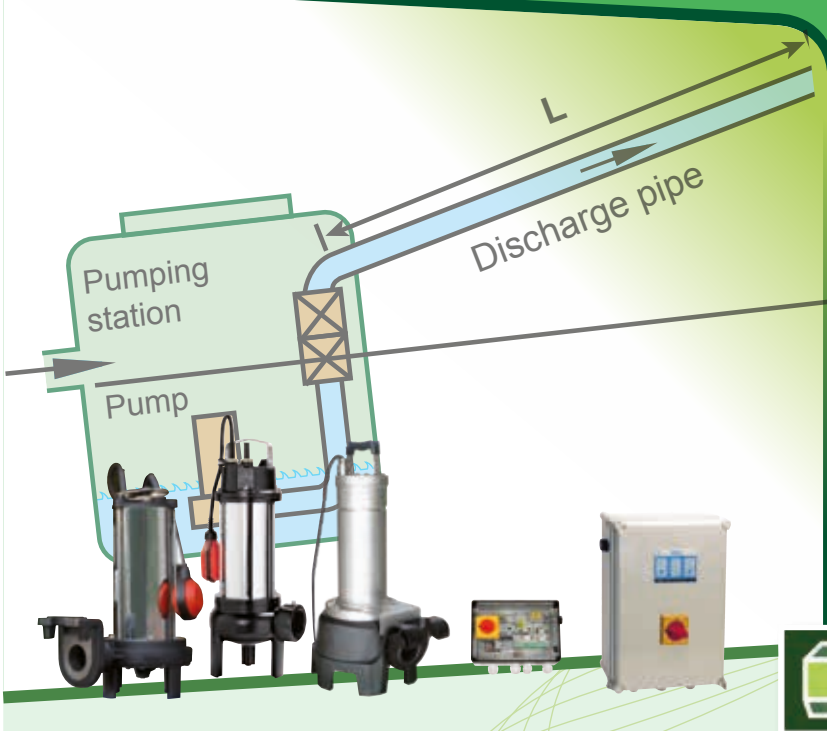

Pumping: the technical guide

Pumping station study _____	p.44
Calculation of the Total Head (TDH) _____	p.45
Electrical control box for 2 pumps _____	p.46
Electrical control box for 1 pump _____	p.47
<i>Installations:</i>	
Star150, 700 and 710 : outdoors installation under green space _____	p. 48
Star900 :	
outdoors installation under concrete slab _____	p. 49
outdoors installation under green space _____	p. 49
Star1000 :	
outdoors installation under green space _____	p. 50
Star1200R :	
outdoors installation under green space _____	p. 51
Srt10, additional valve chamber:	
outdoors installation under green space _____	p. 52
Srt10 : outdoors installation, hydromorphic ground _____	p. 53
The pumping station commissioning maintenance operations _____	p. 54-55
The norms and CE marking _____	p. 56
The recovery of an equipment _____	p. 57



Pumping station study

The realization of a pumping station requires a specific study. The following form associated with a computer program created by Techneau will allow us to determine rapidly the characteristics of your pumping station. To answer precisely your needs, please copy this page, fill it and send it back to us by e-mail to export@techneau.com. You can also consult our website www.techneau.com and download this form, section "Water pumping".

Date:

Jobsite reference:

The maintenance of the pumping station will be done by a water public company?

yes no If yes, please indicate its details:

The effluents: what are they?

*EH: Equivalent user

Storm water	Flow =	m ³ /h
	Surface =	m ²

Waste water	Flow =	m ³ /h
	EH* =	

The altimeter dimensions (see the figure below):

Ground level **NG**: Discharge level **Fer**:

Inlet level **IL**:

Dn1 for the connection to the station:

The discharge:

Length (in meter) **L**:

Dn2 internal:

Pipe type: PVC PEHD Cast-iron

Other:

The power supply: Three-phase 400 V Single-phase 230 V

The control box (supplied as standard with 10 ml cable):

Installation: indoors outdoors

Distance between the control box and the pumping station: meter(s)

The pumping station:

Installation under: green space road surface

Valve chamber? yes non

Technical specifications yes no provided?

Contact details

Company:

Firstname:

Name:

Direction:

Postcode:

Town:

Tel:

Fax:

E-mail:

Soil configuration

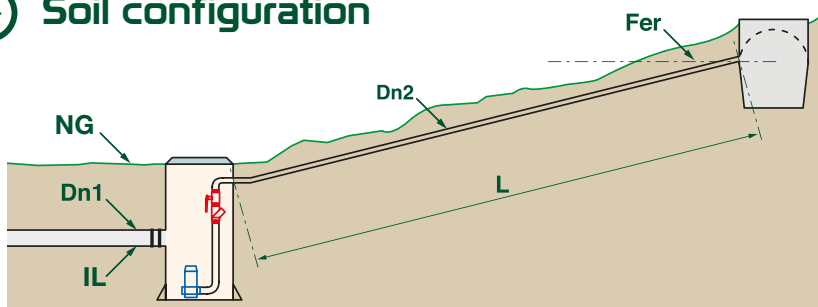

Calculation of the Total Head (TDH)

For each model of pumping station, several pumps are proposed according to the peak flow rate and the total head: make your own calculation and report it on the corresponding pumps graphs.

➤ The peak flow rate (Qp) in m³/h

For wastewater, this flow is calculated according to the number of users (Nb), on the basis of 150 liters a day per user.

The flow of the pump corresponds to the formula: $Qp = \frac{Nb \times 0,150 \times 3}{8} = \dots\dots \text{ m}^3/\text{h}$

➤ The Total Head (TDH)

It corresponds to the geometrical height to be pumped (Hg) + the friction losses in the discharge pipe (L).

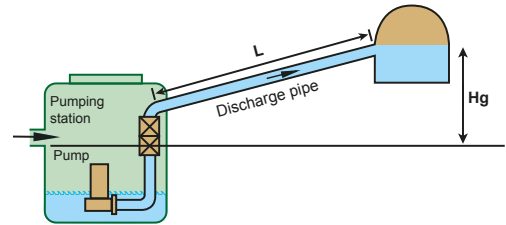

1• For a flow of 5 m³/h:

To guarantee the self-cleaning (v= 0.7 m/s) in a diam. 53/63 pipe, we take into account a minimal flow of 5 m³/h.

Determination of the **TDH** with a PVC diam. 53/63 discharge pressure pipe

Geometrical height	Discharge length in meters											
	10	20	30	40	50	60	70	80	90	100	110	120
1	1,17	1,34	1,51	1,68	1,85	2,02	2,19	2,36	2,53	2,7	2,87	3,04
2	2,17	2,34	2,51	2,68	2,85	3,02	3,19	3,36	3,53	3,7	3,87	4,04
3	3,17	3,34	3,51	3,68	3,85	4,02	4,19	4,36	4,53	4,7	4,87	5,04
4	4,17	4,34	4,51	4,68	4,85	5,02	5,19	5,36	5,53	5,7	5,87	6,04
5	5,17	5,34	5,51	5,68	5,85	6,02	6,19	6,36	6,53	6,7	6,87	7,04
6	6,17	6,34	6,51	6,68	6,85	7,02	7,19	7,36	7,53	7,7	7,87	8,04
7	7,17	7,34	7,51	7,68	7,85	8,02	8,19	8,36	8,53	8,7	8,87	9,04
8	8,17	8,34	8,51	8,68	8,85	9,02	9,19	9,36	9,53	9,7	9,87	10,04

2 • For a flow of 10 m³/h:

To guarantee the self-cleaning (v= 0.7 m/s) in a diam. 63/75 pipe, we take into account a minimal flow of 10 m³/h.

Determination of the **TDH** with a PVC diam. 63/75 discharge pressure pipe

Geometrical height	Discharge length in meters											
	10	20	30	40	50	60	70	80	90	100	110	120
1	1,15	1,3	1,45	1,6	1,75	1,9	2,05	2,2	2,35	2,5	2,65	3,8
2	2,15	2,3	2,45	2,6	2,75	2,9	3,05	3,2	3,35	3,5	3,65	4,8
3	3,15	3,3	3,45	3,6	3,75	3,9	4,05	4,2	4,35	4,5	4,65	5,8
4	4,15	4,3	4,45	4,6	4,75	4,9	5,05	5,2	5,35	5,5	5,65	6,8
5	5,15	5,3	5,45	5,6	5,75	5,9	6,05	6,2	6,35	6,5	6,65	7,8
6	6,15	6,3	6,45	6,6	6,75	6,9	7,05	7,2	7,35	7,5	7,65	8,8
7	7,15	7,3	7,45	7,6	7,75	7,9	8,05	8,2	8,35	8,5	8,65	9,8
8	8,15	8,3	8,45	8,6	8,75	8,9	9,05	9,2	9,35	9,5	9,65	10,8

Example: Calculation of the **flow** and **TDH** for **20** users, with a geometrical height pumped of **4** m, and a **70** m discharge length, PVC 53/63 discharge pressure pipe..

$$\text{Flow (Qp)} = \frac{20 \times 0,150 \times 3}{8} = 1,125 \text{ m}^3/\text{h}$$

We consider a minimal flow of 5 m³/h (self-cleaning).

TDH (see above table)= 5.19 m.

The pump will thus process a flow of 5 m³/h at 5.19 m. **You can select the pump n°9.**

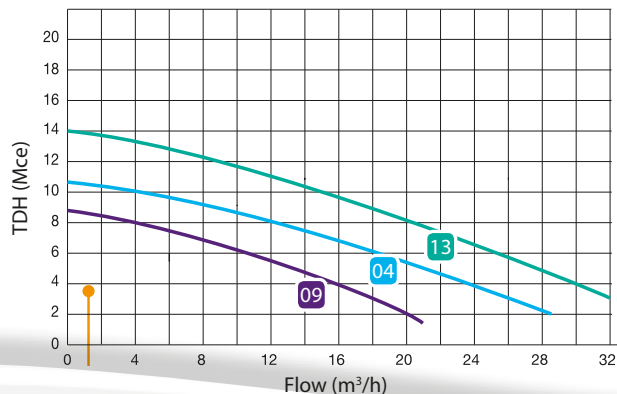

Secure your pumping installation

Control and protection box for 2 pumps.

SRI control box



- The level management relies on a pressure probe. The stainless steel piezo probe is either mounted in a duct, or mounted in a chain with counterweight. It provides an instant and precise measure of the effluent level. Its robustness is well known in the sewerage sector.
- The box protects the pumps against overcurrents.
- For the pumps equipped with embedded thermistors, the box also protects the pumps against overheatings.

Technical features:

- Single-phase 230 volts or four-phase 400 volts + neutral.
- Automatic operation of the pumps depending on the tank level.
- Automatic reverse to every start.
- Audible and visual alarm on alarm float.
- Lockable disconnecter.
- Forced March function of the pumps with push-button.
- Pump visualisation March-Disjunction.
- Dry contact for alarm report.
- **Dimensions : L 300 x D 140 x H 380 mm**



How it works?

- Combined with an alarm float, the box signals the overflow risks in case of overhead or defect.
- In case of defect of the pressure measurement system, the degraded operating mode is ensured by the regulator. The box signals the anomaly by displaying: "sensor fault".

References Selection:

Single-phase 230V	Four-phase 400 V + neutral
dual-voltage from 1.6 to 2.5 A: CSJ201	
dual-voltage from 2.6 to 4.0 A: CSJ202	
dual-voltage from 4.1 to 6.3 A: CSJ204	
dual-voltage from 6.4 to 10.5 A: CSJ206	
from 9 to 12 A (with capacitors integrated to the box): CSJ209	-

Installation only inside.

OUR
ADVICE

“For an outdoors installation, a protection cabinet is necessary. It will more secure your electrical installation.”

Cabinet with base for outdoors installation

Polyester. Dimensions: L 540 x H 520 x D 240 mm + base height 580 mm.
To install a 1 or 2 pumps electrical control box.
With earth connection.

CP510



Warning

Techneau's pump control boxes connect to a power supply equipped with a bipolar or tripolar protection device, depending on the cases, complying with the EN 60204 standard.



Electrical control box for 1 pump

Model CPO3

Usage

- **Management and control box for a single phase pump** with 5A max embedded float (RB10 option).
It protects the pump against overcurrents.



Technical features:

- Pump with integrated float, 230 V single phase with 5A maxi,
- Waterproofness IP54,
- Display of the pump on,
- Information on the inactivity of the pump for more than 24 hours with an indicator, reset to first start,
- Information on an unusually long operating time of the pump: indicator + audible alarm,
- Anti-overflow safety. Plan to add a RB10 alarm float (not included),
- Alarm report.

How it works?

Box details

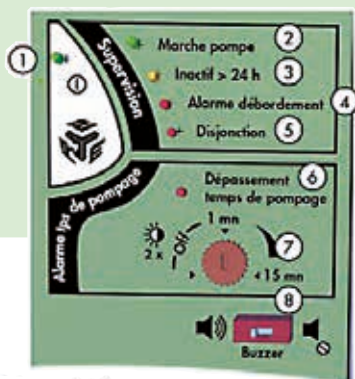

- 1 Voltage presence indicator,
- 2 Pump on indicator,
- 3 Inactivity over 24h indicator,
- 4 Overflow alarm indicator (if the alarm is connected),
- 5 Overload circuit-breaker indicator,
- 6 Pumping time exceedance indicator,
- 7 Setting of the pump's max operating time before alarm,
- 8 Switching/inhibition of the audible alarm.



Warning

Techneau's pump control boxes connect to a power supply equipped with a bipolar or tripolar protection device, depending on the cases, complying with the EN 60204 standard.

STAR150 Outdoors installation under green 700 and 710 space and hydromorphic ground



Warning, control box installation

Techneau's pump control boxes connect to a power supply equipped with a bipolar or tripolar protection device, depending on the cases, complying with the EN 60204 standard.

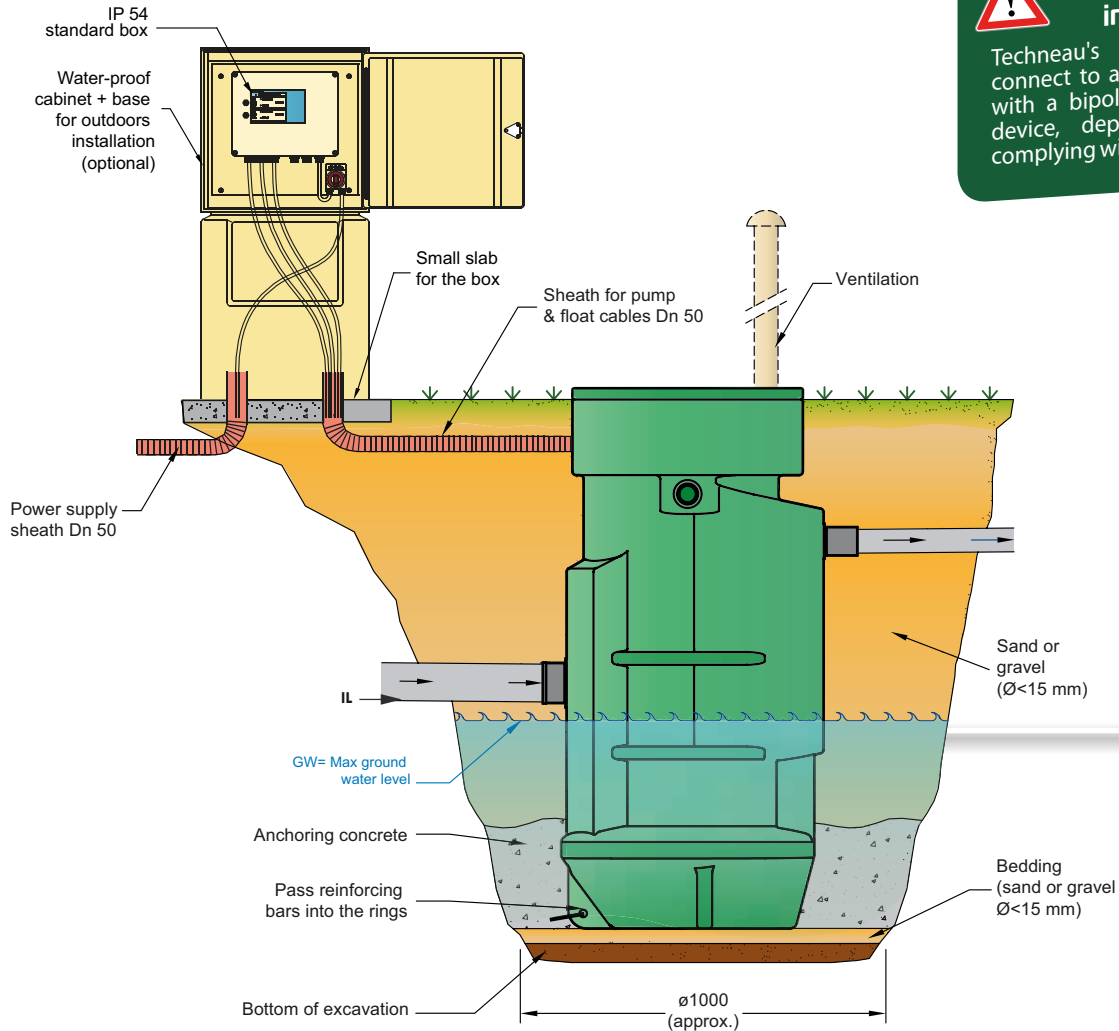

- The standard box must be placed away from bad weather. The cabinet + base (option ref. CP510) allow to install the box outside.
- In addition to the electrical disconnection/protection device, an earth connection is required.
- Only one extension (H 400 mm) is possible on Star700 and 710

- No possible extension if there is ground water.
- **Maximum ground water level:**

	STAR150	STAR700	STAR710
Without extension	GW* ≤ standard IL		
With extension	The tank mustn't be into contact with the ground water.		

*GW: maximum ground water level (Ground Water or run-off water).
IL: Inlet level.

Only the manual supplied with the device prevails.
For any other installation configurations, please contact us.



STAR900 Outdoors installation under concrete slab and hydromorphic ground

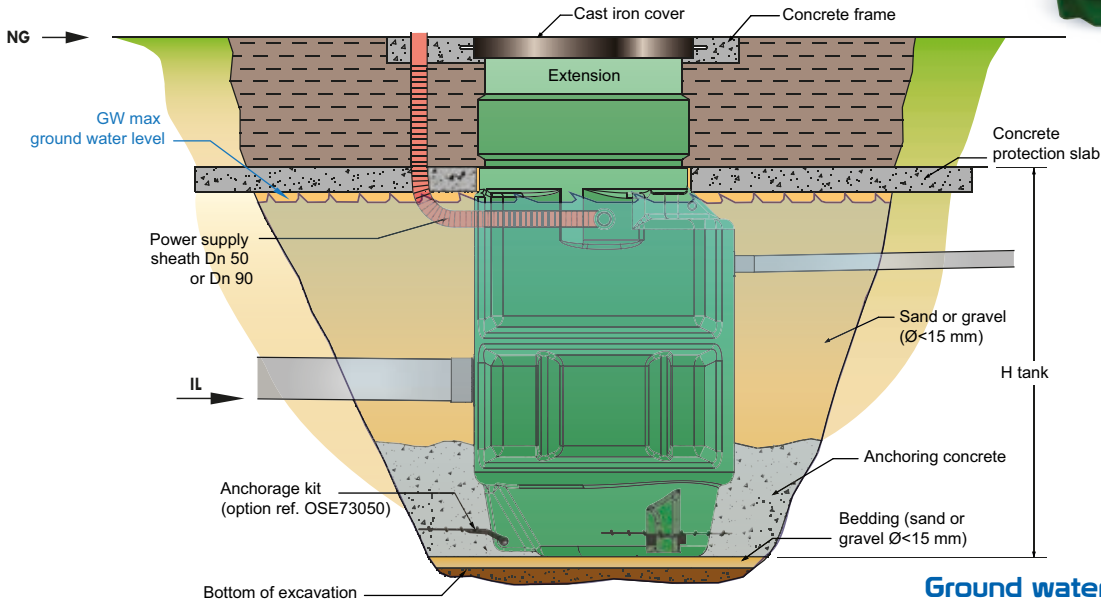

Ground water level

With or without extension(s), it depends on the installation configuration and on the tank model.

Configuration	STAR900
With extension	$GW^* \leq H \text{ tank}$
Without extension	$GW^* \leq NG$

* NG: Natural Ground / IL: Inlet Level / GW: maximum ground level (ground water or run-off water) / H tank (without extension)

Important notes

- Star900 stations can support a maximum of 1 extension by access. The extensions are telescopic or fixed depending on the tank models: ref. ETR041 or ETR060.
- In case of road installation, a protection slab for the backfilling vertical loads is mandatory.
- In no case the vertical loads (buffer, frame and slab) must lean on the tank or on the polyethylene extension.
- The concrete slabs will be calculated taking into account the different requests (backfilling height, passage of vehicles).

STAR900 Outdoors installation under green space

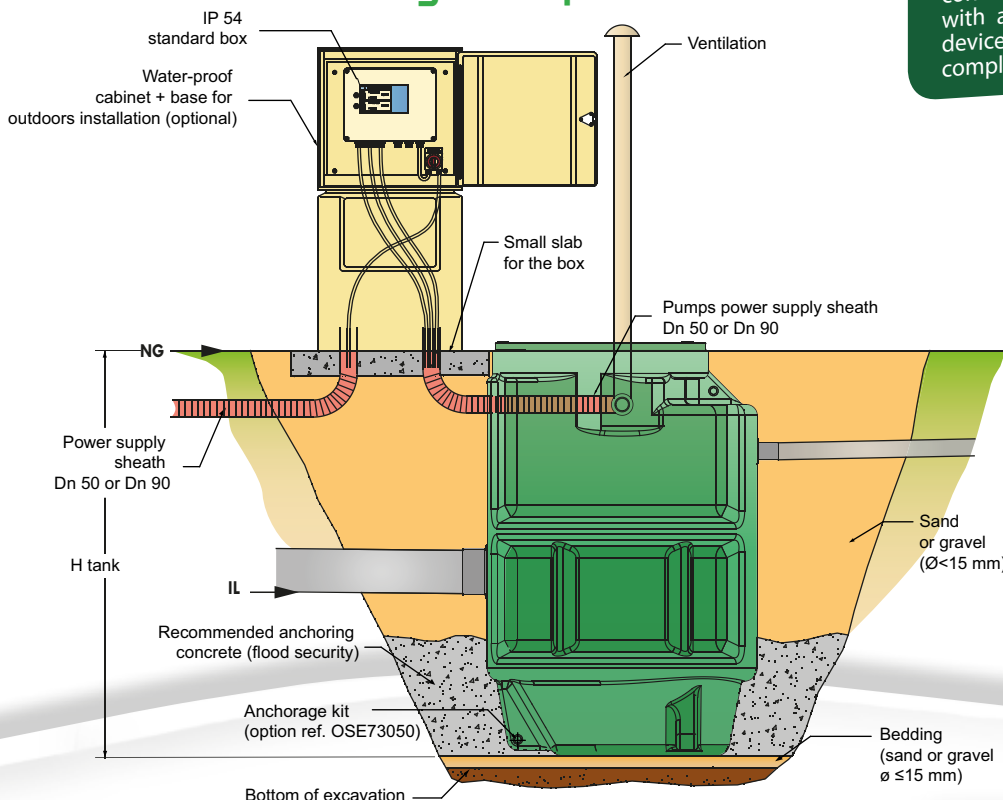

Warning, control box installation
 Techneau's pump control boxes connect to a power supply equipped with a bipolar or tripolar protection device, depending on the cases, complying with the EN 60204 standard.



Only the manual supplied with the device prevails.
 For any other installation configurations, please contact us.

www.techneau.com

2018 edition

STAR1000

Outdoors installation under green space



Schematic diagram,
base STAR1000 Height 2 m

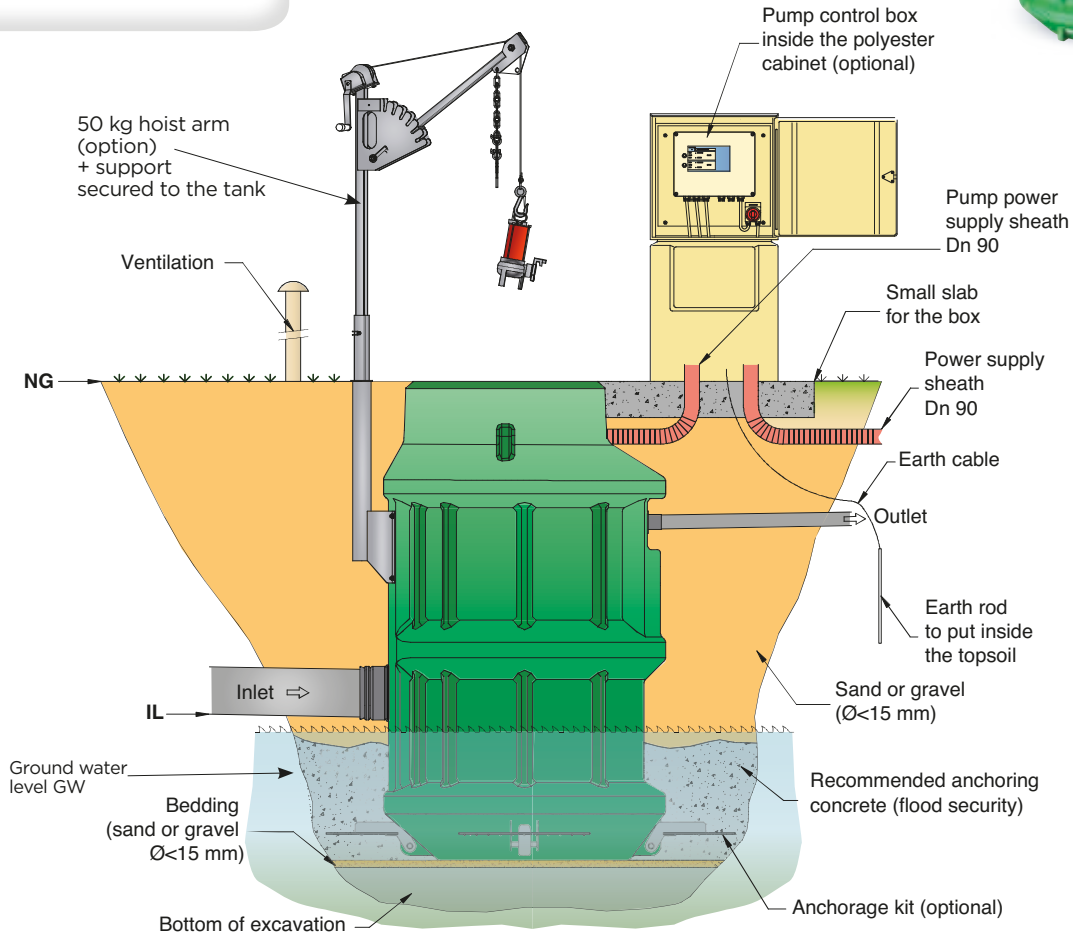

Important notes

- > Star1000 stations can support a maximum of 1 extension by access. The extensions are telescopic or fixed depending on the tank models: [ref. RE207 or TCRE207](#).
- > In case of road installation, a protection slab for the backfilling vertical loads is mandatory.
- > In no case the vertical loads (buffer, frame and slab) must lean on the tank or on the polyethylene extension.
- > The concrete slabs will be calculated taking into account the different requests (backfilling height, passage of vehicles).

> Ground water level

With or without extension(s), it depends on the installation configuration and on the tank model.

Configuration	STAR1000
With extension	$GW^* \leq IL$
Without extension	$GW^* \leq NG$

* NG: Natural Ground / IL: Inlet Level / GW: maximum ground level (ground water or run-off water) / H tank (without extension)



Warning, control box installation

Techneau's pump control boxes connect to a power supply equipped with a bipolar or tripolar protection device, depending on the cases, complying with the EN 60204 standard.

Only the manual supplied with the device prevails.
For any other installation configurations, please contact us.



STAR1200R Outdoors installation under green space vert

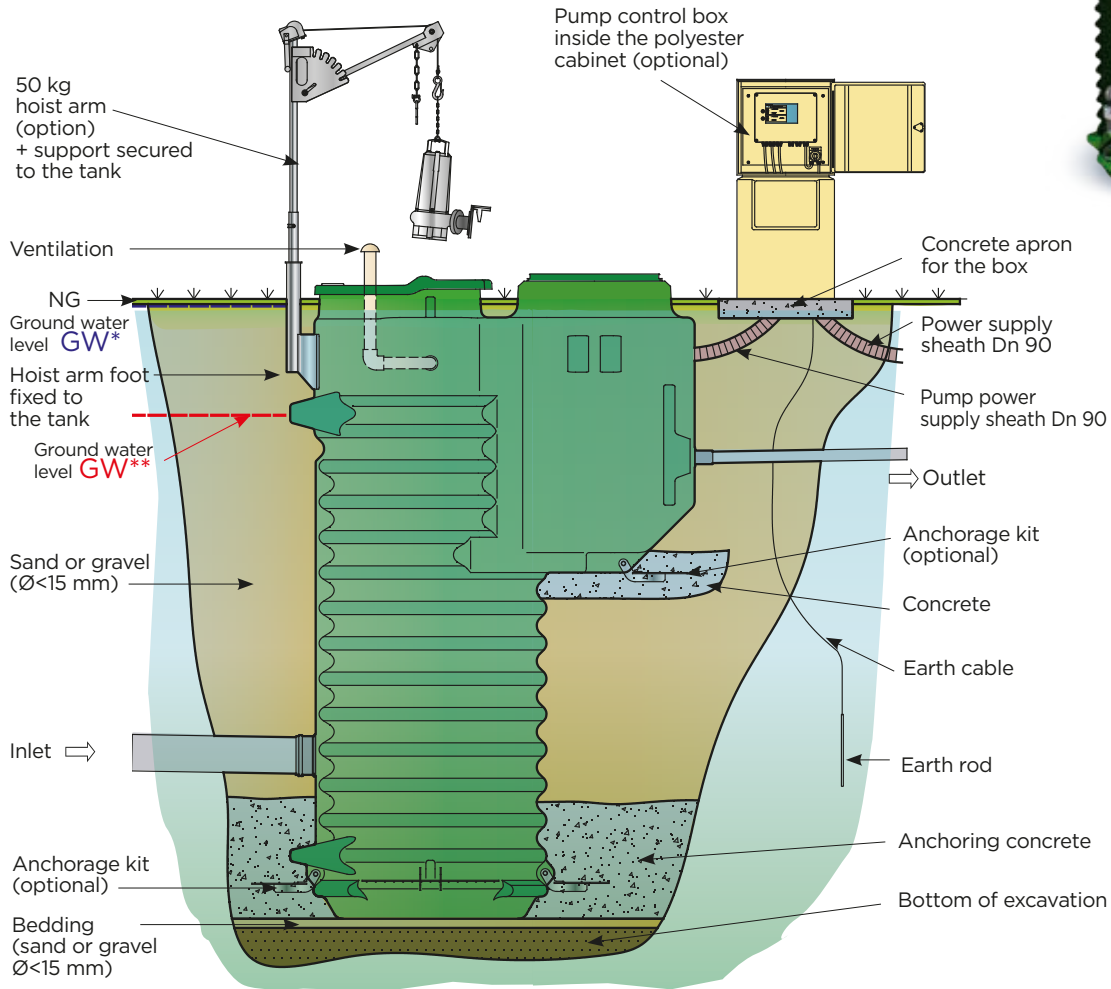

- ⊕ Perform an excavation depending on the tank's size.
- ⊕ Place the earth rod inside the topsoil.
- ⊕ Place the station on a 100 mm bedding (sand or gravel Ø < 15 mm).
- ⊕ Deploy the anchorage kit from the tank and from the valve chamber (optional).
- ⊕ Stabilise the tank by filling in clean water (100 to 200 L).
- ⊕ Pour the anchoring concrete (it is required to ballast the station in case of a law draining ground or a risk of rising ground water).
- ⊕ Note: depending on the quantity of concrete used, it might be necessary to add clean water in the station.
- ⊕ Process gradually by balancing the levels of the water inside and of the concrete outside.
- ⊕ Connect the pipes and backfill with 10/15 gravel up to the valve chamber's base.
- ⊕ Pour concrete (liquid enough) at the bottom of the valve chamber.
- ⊕ Finish to backfill with 10/15 gravel.
- ⊕ A power supply protection device is required.

Warning, control box installation

Techneau's pump control boxes connect to a power supply equipped with a bipolar or tripolar protection device, depending on the cases, complying with the EN 60204 standard.

Ground water level:

	Station H	GW
* CB1225/30/35/40	Up to 4m	GW = NG
** CB1245	4,5 m	GW = (NG - 500 mm)

Only the manual supplied with the device prevails.
For any other installation configurations, please contact us.

SRT10 Outdoors installation under green space



Schematic diagram, base SRT10 with valve chamber

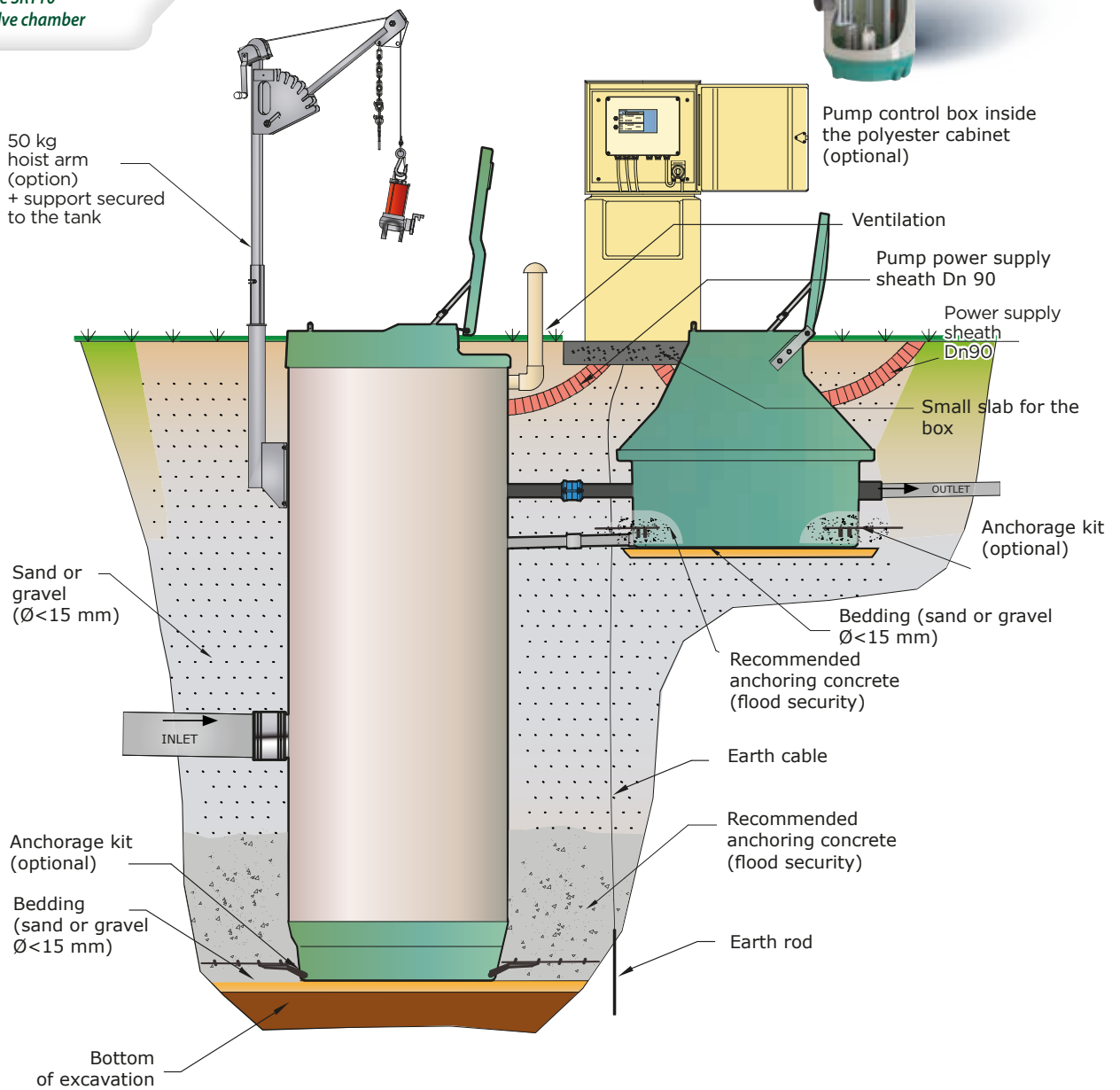

- Perform an excavation depending on the tank's and valve chamber's sizes.
Place the earth rod.
Place the station and the valve chamber on a 30 mm bedding (sand or gravel Ø < 15 mm).
Deploy the anchorage kit (option) from the tank and from the valve chamber or pass reinforcing bars into the rings.
- Pour an anchoring concrete, flood security (highly recommended).
- Connect the pipes and backfill with 10/15 gravel.
- A power supply protection device is required.



Warning, control box installation

Techneau's pump control boxes connect to a power supply equipped with a bipolar or tripolar protection device, depending on the cases, complying with the EN 60204 standard.

Only the manual supplied with the device prevails.
For any other installation configurations, please contact us.

SRT10

Outdoors installation under green space and hydromorphic ground

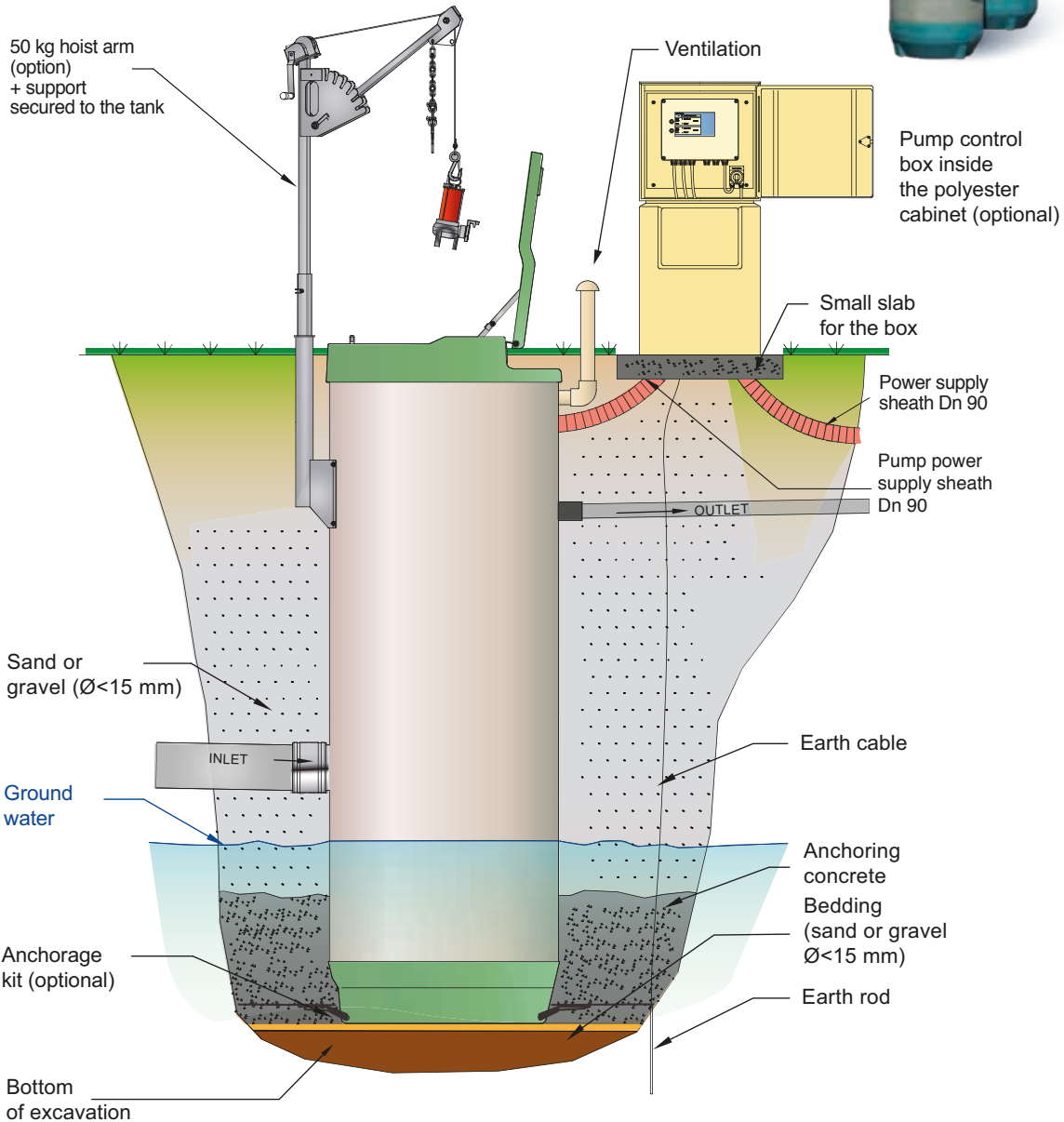

Pump control box inside the polyester cabinet (optional)

- Perform an excavation depending on the tank's sizes.
Place the earth rod.
Place the station on a 30 mm bedding (sand or gravel $\text{Ø} < 15 \text{ mm}$).
Deploy the anchorage kit (option) from the tank and from the valve chamber or pass reinforcing bars into the rings.
- Simultaneously and gradually pour an anchoring concrete and add clean water in the station.
- Connect the pipes and backfill with 10/15 gravel.
- A power supply protection device is required.

Warning, control box installation

Techneau's pump control boxes connect to a power supply equipped with a bipolar or tripolar protection device, depending on the cases, complying with the EN 60204 standard.

Only the manual supplied with the device prevails.
For any other installation configurations, please contact us.

Pumping the commissioning of a pumping station

Reminder: our pumping stations except Star1000, Star1200R and PUP are delivered pre-connected: the regulation system and the pumps are connected to the control box.



Items to include by the installer of the station:

- 1 • Laying of the pumping station and connection to the different pipes,
- 2 • Include a Dn 90 duct between the main box and Techneau's control box,
Do not forget to run through the main power cable,
The latter must be connected to the control box.
- 3 • Also include 2 Dn 90 ducts between the station and Techneau's control box to run through the cables of the pumps, level regulators and/or the probe.
- 4 • Installation of the main power box, earth-leak circuit breaker and of the disconnecter if applicable.
- 5 • Draining and cleaning up of the pumping station as well as the upstream network before commissioning.
- 6 • Provision of lifting medium fitted for handling the pumps the day of the commissioning of the pumping station.
- 7 • Control, by an approved body, of the electrical installation

Note: this control and Advice request can be subcontracted to Techneau.

- 8 • Connect the electrical cable from the main box to our control box.
- 9 • Plug in and verify the direction of rotation of the pumps.
- 10 • Place the pumps onto the support bases and fasten the cables.
- 11 • Connect the level regulators and/or the probe to the control box (depending on the model).
- 12 • Verify the proper functioning of the installation.
- 13 • Perform the tests in water.

Some recommendations

- Don't forget to measure the length of your ducts before you burry them.
- In the case of a cage screen, the covers shall be easily manoeuvrable: avoid cast iron covers too heavy, hard to handle by the person in charge of the maintenance.
- To make maintenance operations easy, the pump control box shall be as close as possible to the pumping station.
- If the cables are long, include a draw-in box at least every 40m.
- In the case of a piezo probe, if its length exceeds 10m, include a CAPIBOX connection box.
- Avoid concrete reducing heads.



A pumping station and its equipment are solicited on a daily basis and constantly exposed to aggressive liquids (ex. waste water) and plugging agents (ex. lubricants).

A regular and preventive maintenance avoids a premature wear of the materials and resulting malfunctions. It also increases the durability of your pumping station.

The frequency of the maintenance depends on the nature of the circulating water. However, we advise at least 3-4 visits per year.

To this end, our field technicians, specially trained to controls and to the maintenance of your pumping equipment, are available all over metropolitan France.

Moreover, a hotline (+33 2 33 77 21 19) is available, should you have any questions. You can also email us via maintenance@techneau.fr

➤ The maintenance for each visit in 10 steps:

- 1 • Shut down the power supply,
- 2 • *Model with floats:*
Take the floats out of the tank, clean them up properly and remove the solids held onto the floats,
- 2^{bis} • *Piezo model (SRI):*
Take out the probe, remove the cap in case of clogging, clean up using a rag,
Do not use pressure, do not use a harmful tool on the membrane.
Put the probe back and verify its setting.
- 3 • Remove the large pieces of lubricants located at the surface
- 4 • Power on the pump in manual or forced operation and have it discharge until loss of prime in order to empty the tank as much as possible.
- 5 • Flush with a large volume of water the interior walls of the tank as well as the pipes and the accessories into contact with the effluent. Make sure that the pump is properly re-primed.
- 6 • Verify the automation sequences of the control box.
- 7 *Twice a year:*
 - Take out the pumps, flush with a large volume of water the suction housing of each pump. Verify the wheel status, as well as the quality of the oil if the pumps are equipped with an oil reserve (see manufacturer's manual).
 - Put the pumps back, fill in the station with clear water, power on the pumps and verify the amperage.
 - Have verified the items of the electrical installation by an authorized body.
- 8 • *Once a year:*
The station will be entirely drained and flushed with a large volume of water.
- 9 • In the case of a cage screen:
The clean up frequency of the cage screen shall be adapted to the load of wastes.
We advise a clean up at least every 2 weeks.
- 10 • We advise to choose a maintenance contract with a specialized company.

Only the manual supplied with the device prevails.



Tests bench: control of the specifications of a pumping station

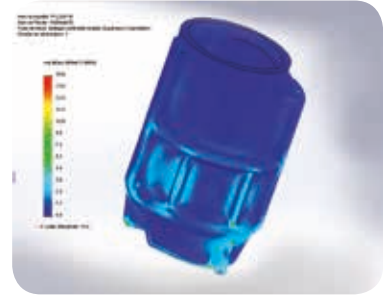

➤ Tests, certification and products tests:

Techneau has been ISO 9001 certified for more than 15 years.

All our products are tested and validated before their commercialisation. Our design office and our tests bench integrated to our production site allow us to propose you products conform to the norms in force.

➤ An appropriate training:

In our company based in Marigny we can propose you to get in-depth training in:

- our whole range of products, their specifications, their functioning, their use and the rules to respect,
- market informations, the sales and also the rules in force.

Techneau training or how answering to our clients needs or expectations



Equipment part-exchange Form

- 1 - Contact the sales department to get a return number which will have to be appended here
- 2 - Send it then by e-mail: info@techneau.com or by fax +33 2 33 56 61 93



	Return number <i>(imperative otherwise the equipment will be refused)</i>		
Customer:		Delivery note number:	
Contact :		Fax n° / e-mail	

Equipment concerned:.....

Reason for part-exchange

The return transport

Organized by Techneau:

Possible date of shipment:

Shipment address:

Organized by you:

The return conditions:

Initial amount (A)	HT €
<i>Price of the "one-way" delivery (B)</i>	HT €
<i>Price of the return transport (C)</i>	HT €
<i>Equipment discount* amount (D)</i>	HT €
Total amount of the part-exchange (A - (B+C+D))	HT €

 * The amount of the discount could be reviewed after full inspection of the equipment upon receipt in our workshops.

Customer return acknowledgement

First name - Name - Function

Stamp of your company:



Tailor-made manufacturing
for pumping stations till
diam. 2m90



Techneau

is also

WATER ENGINEERING

- **Water treatment**

Oil and grease separators,
Stormwater treatment units,
dry-docks units

- **Hydraulic equipments:**

Flow regulators
HydroVortex flow controllers
Penstocks

FLOOR DRAIN EQUIPMENTS

- **Manhole covers**
- **Siphons**
- **Stainless steel floor drains & gutters**

Tel: +33 2 33 77 58 05
e-mail : eqs@techneau.com

Our commitment to
water sports



Your distributor:

www.techneau.com

Z.A La Chevalerie
50570 MARIGNY-LE-LOZON
Tel: +33 (0)2 33 56 62 08
Fax: +33 (0)2 33 56 61 93
E-mail : info@techneau.com

Techneau is a part of *Gaeau* group